

ZEXEL - TEST VALUES
Injection pumps

BOSCH No.	:	9 400 610 221	1/4
ZEXEL No.	:	101695-3202	
Date	:	31.10.1992	[3]
Company	:	KOMATSU	
Engine	:	S6D95L / 6207-71-1451	

IP-Type number : 101069-9430 / PES6A
Governor type number : 105400-8040 / EP/RSV

TEST PREREQUISITES

Test oil : ISO-4113
Test oil inlet temperature °C : 40.00...45.00
Inlet pressure bar : 1.6
Test nozzle holder combination : 1 688 901 013
Opening pressure bar : 175
Test pressure line
Inner x Outer Dia - Length mm : 2.00 x 6.00 x 600

PORT CLOSING

Prestroke mm : 3.6 ± 0.05
Rod position mm : -
Port closing mark Cyl. No. : -
Cam sequence : 1-5-3-6-2-4

Port closing mark Cyl. No. : -
Port closing difference °NW : 0-60-120-180-240-300

Tolerance +- °C: 0.50 (0.75)

A1

ZEXEL - Test values
Injection pumps



Injection Quantity :

Adjusting Point	Rack Pos. (mm)	P. Speed (rpm)	Injection Q'ty (cm ³ /1000 str.)	Difference (%)	Fixed	Remarks
A	12.2	750	62.7 ± 1.0	± 2.5	Rack	Basic
	approx.10.0	400	12.5 ± 1.0	± 15.0	Rack	
A	12.2	750	62.7 ± 1.0	-	Lever	Basic

Timing Advance Specification :

Pump Speed (rpm)						
Advance Angle (deg)						

A2

ZEXEL - Test values
Injection pumps



A3

ZEXEL - Test values
Injection pumps



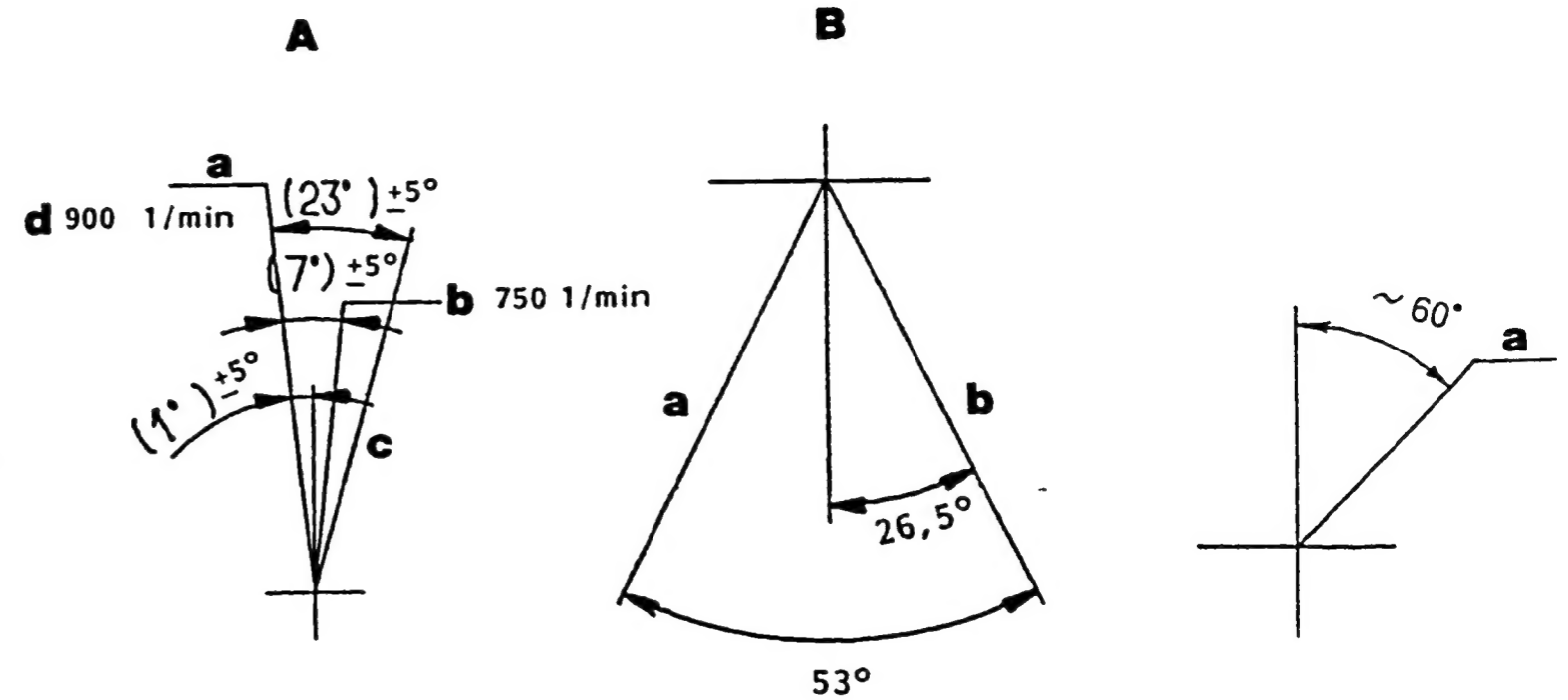
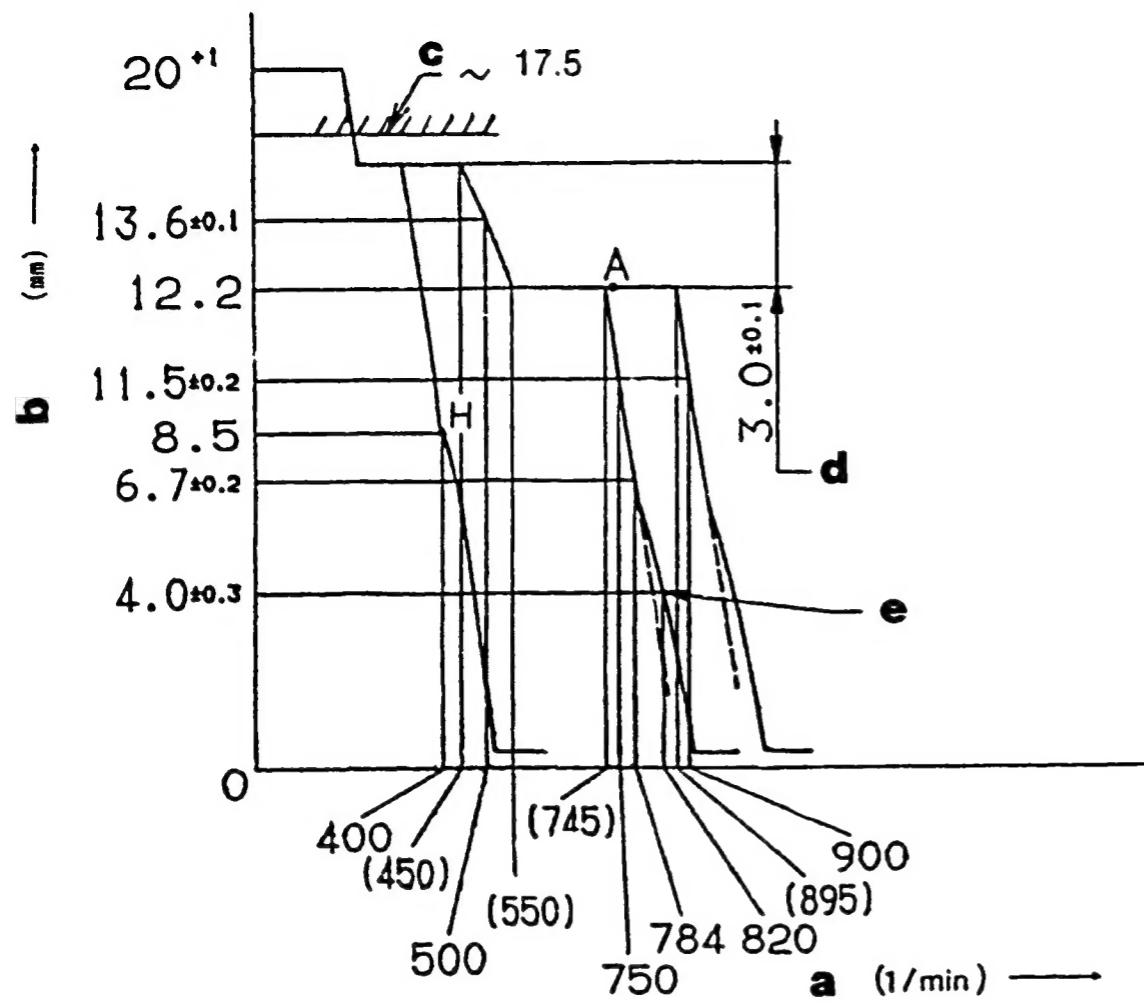

Figure 75

GOVERNOR ADJUSTMENT

Recommended speed droop adjustment screw position: 12

101695-3202 2/4

- a = Pump speed
- b = Control rack position
- c = Control rack limit:
- d = Difference in control rack position between 750 rpm and 400 rpm
- e = Idle-sub spring setting:

A = Speed Control Lever Angle

- a = Full-speed
- b = Setting:
- c = Idling
- d = Setting: (on our shipment)

TIMING SETTING

At No. 1 plunger's beginning of injection position.

a = Key position

B = STOP LEVER ANGLE

- a = Stop
- b = Normal

A4

ZEXEL - Test values
Injection pumps



A5

ZEXEL - Test values
Injection pumps



■ Note

- Before adjustment, remove the idling sub spring.
- Move the control lever fully in the stop direction, and set the minimum-speed stopper bolt so that the control rack position is 0.5 - 1.0 mm.

■ ADJUSTMENT

		Pump Speed (rpm)	Rack Position (mm)	Boost pressure kPa (mmHg)	Remarks
Full-load Adjustment (Temporary)		1100 600	12.2 12.2	-	<ul style="list-style-type: none"> • Adjust using screw (2) • Adjust using screw (1)
Torque Control Spring Adjust- ment	1.st stroke	approx. 350 500 approx. 500	15.2 13.6 12.2	-	<ul style="list-style-type: none"> • Adjust using spring capsule (4) • Confirm • Confirm the torque control stroke is: 3.0 ± 0.1 mm
	2.st stroke	-	-	-	<ul style="list-style-type: none"> • Adjust using spring capsule (4) • Confirm • Confirm the torque control stroke is: (mm)
Maximum-speed Adjustment		750 784 900	12.2 6.7 10.5 ± 0.2	-	<ul style="list-style-type: none"> • Fix the control lever • Confirm speed droop - adjust using screw (3) • Confirm
Boost Compensator System		-	-	-	<ul style="list-style-type: none"> • Fix the control lever • Adjust using screw (6) • Confirm the boost compensator stroke is: (mm)
Idling Adjustment		820	4.0 ± 0.3	-	<ul style="list-style-type: none"> • Fix the control lever • Adjust using spring capsule (5) • Confirm
1. Idling Sub Spring					
2. Control Lever	H	400	8.5	-	<ul style="list-style-type: none"> • Adjust using the control lever
Full-load Adjustment		750	12.2	-	<ul style="list-style-type: none"> • Adjust using screw (1)
Control Lever Angle Measurement		<ul style="list-style-type: none"> • Measure the control lever angle at the "idling" and "full" positions. • When the control lever is depressed toward the "full" position, replace the shifter's shim with a thicker one. • When the control lever is depressed toward the "idling" position, replace the shifter's shim with a thinner one. 			
Control Rack Limiter Adjustment		0	approx. 17.5	-	<ul style="list-style-type: none"> • Adjust using screw

A6

ZEXEL - Test values
Injection pumps



A7

ZEXEL - Test values
Injection pumps



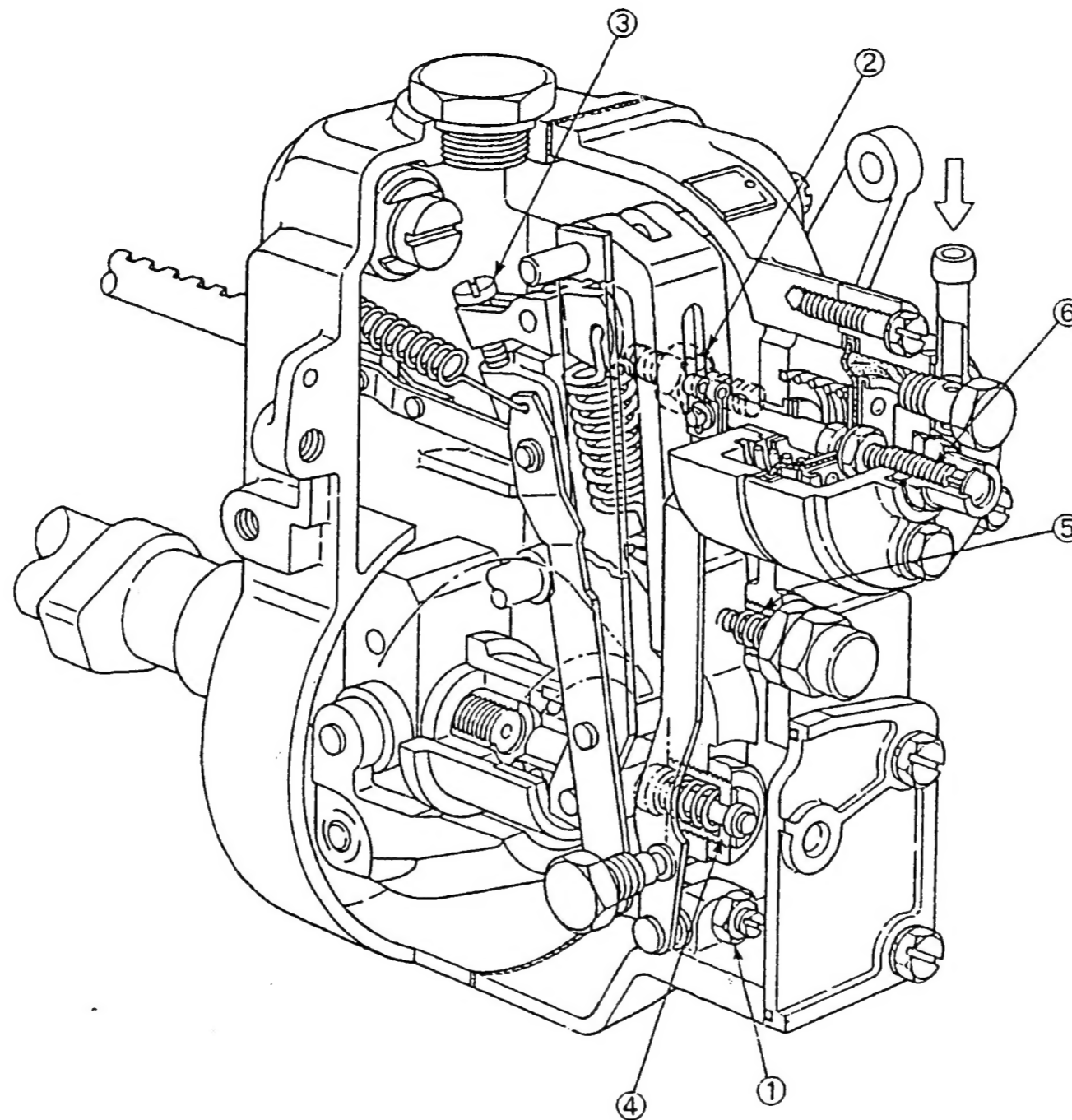

Figure 76

- 1 = Screw
- 2 = Screw
- 3 = Screw
- 4 = Spring capsule
- 5 = Spring capsule
- 6 = Screw

101495-3202 4/4

A8

ZEXEL - Test values
Injection pumps



A9

ZEXEL - Test values
Injection pumps



ZEXEL - TEST VALUES
Injection pumps

BOSCH No.	:	9 400 610 222	1/4
ZEXEL No.	:	101695-3580	
Date	:	31.10.1992	[0]
Company	:	KOMATSU	
Engine	:	6D95L / 6206-71-1460	

IP-Type number	:	101069-9141 / PES6A
Governor type number	:	105400-7460 / EP/RSV

TEST PREREQUISITES

Test oil	:	ISO-4113
Test oil inlet temperature °C	:	40.00...45.00
Inlet pressure bar	:	1.6
Test nozzle holder combination	:	1 688 901 013
Opening pressure bar	:	175
Test pressure line	:	
Inner x Outer Dia - Length mm	:	2.00 x 6.00 x 600

PORT CLOSING

Prestroke	mm	:	3.6 ± 0.05
Rod position	mm	:	-
Port closing mark Cyl. No.	:	:	-
Cam sequence	:	:	1-5-3-6-2-4
Port closing mark Cyl. No.	:	:	-
Port closing difference °NW	:	:	0-60-120-180-240-300
Tolerance	+ - °C	:	0.50 (0.75)

A10

ZEXEL - Test values
Injection pumps



Injection Quantity :

Adjusting Point	Rack Pos. (mm)	P. Speed (rpm)	Injection Q'ty (cm ³ /1000 str.)	Difference (%)	Fixed	Remarks
A	10.3	900	52.0 ± 1.0	± 2.5	Rack	Basic
	approx. 9.1	400	10.5 ± 1.0	± 15.0	Rack	
A	10.3	900	52.0 ± 1.0	-	Lever	Basic

Timing Advance Specification :

Pump Speed (rpm)						
Advance Angle (deg)						

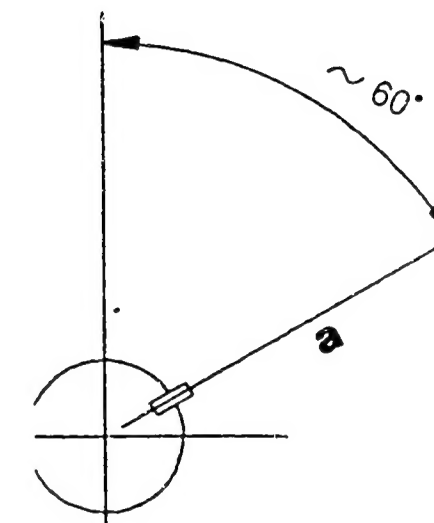
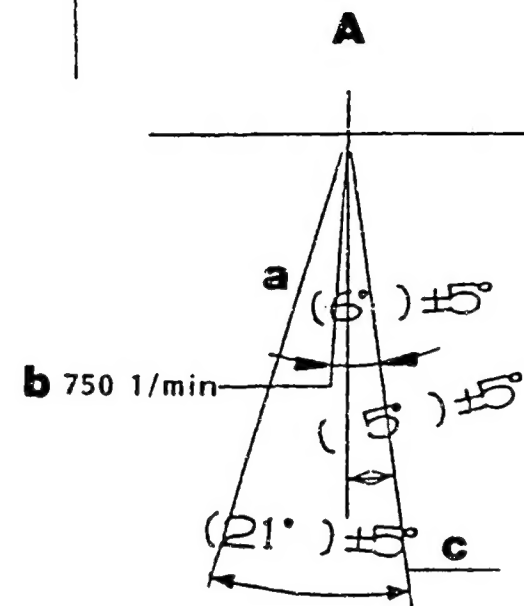
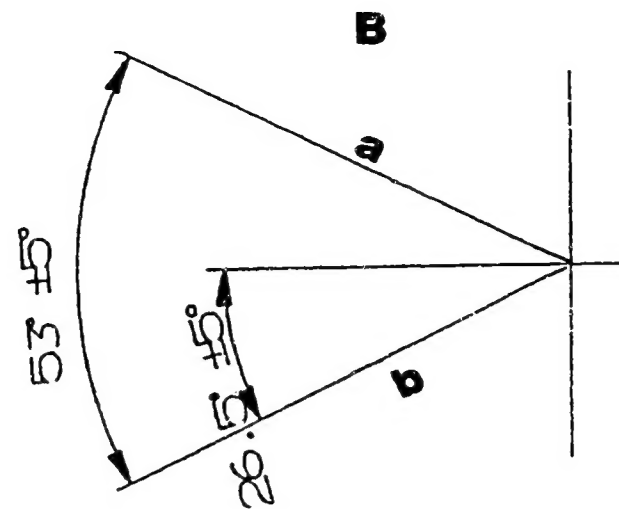
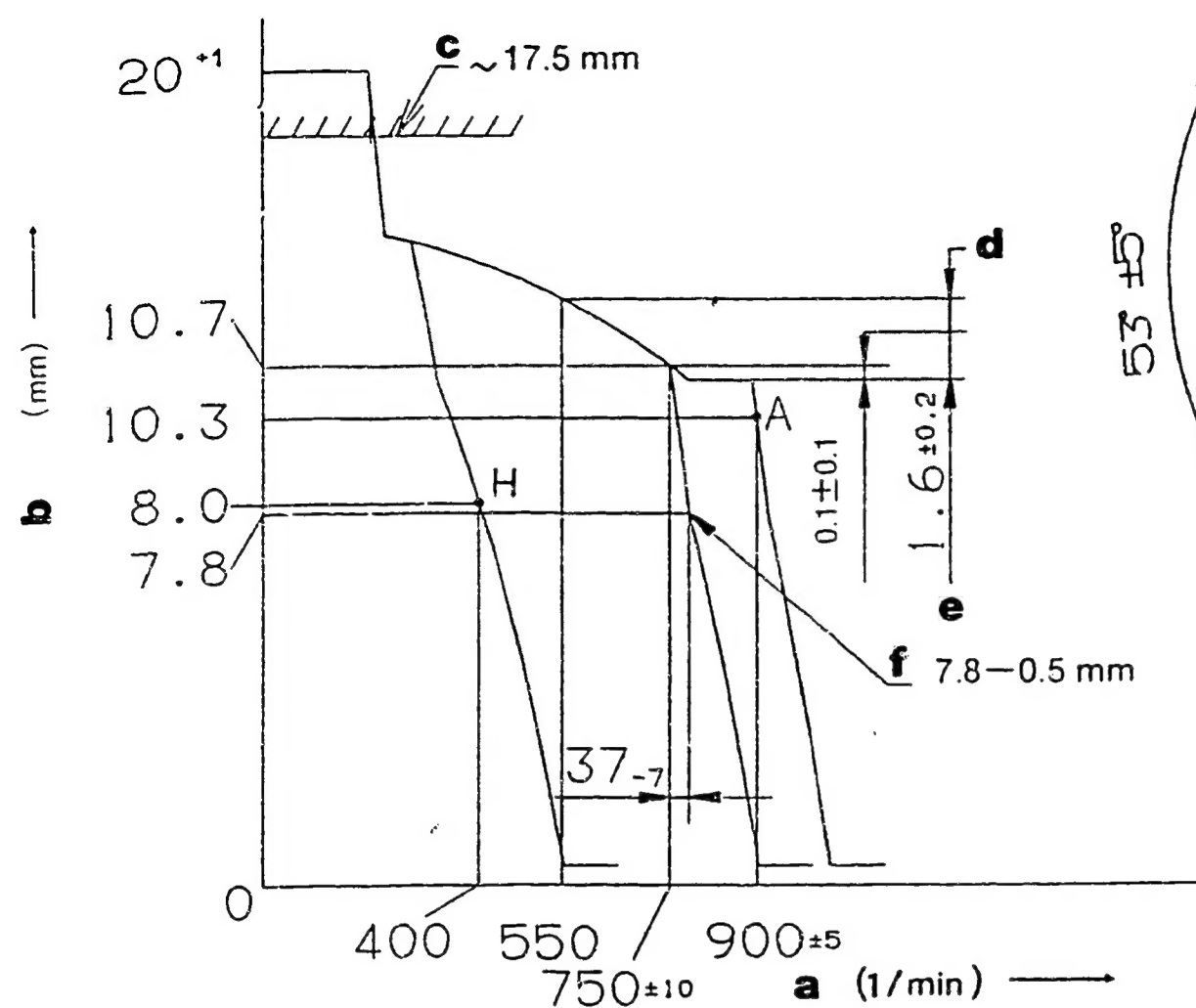

Figure 77

GOVERNOR ADJUSTMENT

Recommended speed droop adjustment screw position: 8

101695-3580 2/4

- a = Pump speed
- b = Control rack position
- c = Control rack limit:
- d = Difference in control rack position between 800 rpm and 550 rpm
- e = Difference in control rack position between 800 rpm and 750 rpm
- f = Idle-sub spring setting:

A = Speed Control Lever Angle

- a = Idling
- b = Setting:
- c = Full-speed

B = STOP LEVER ANGLE

- a = Stop
- b = Normal

■ TIMING SETTING

At No. 1 plunger's beginning of injection position.

a = Camshaft key groove position

A13

ZEXEL - Test values
Injection pumps



A14

ZEXEL - Test values
Injection pumps



■ Note

- Before adjustment, remove the idling sub spring.
- Move the control lever fully in the stop direction, and set the minimum-speed stopper bolt so that the control rack position is 0.5 - 1.0 mm.

■ ADJUSTMENT

		Pump Speed (rpm)	Rack Position (mm)	Boost pressure kPa (mmHg)	Remarks
Full-load Adjustment (Temporary)		1100 600	10.3 10.6	-	<ul style="list-style-type: none"> • Adjust using screw (2) • Adjust using screw (1)
Torque Control Spring Adjust- ment	1.st stroke	550 750 ± 10	12.2 10.7	-	<ul style="list-style-type: none"> • Adjust using spring capsule (4) • Confirm • Confirm the torque control stroke is: (mm)
	2.st stroke	-	-	-	<ul style="list-style-type: none"> • Adjust using spring capsule (4) • Confirm • Confirm the torque control stroke is: (mm)
Maximum-speed Adjustment		750 ± 10 750+37 +30	10.7 7.8	-	<ul style="list-style-type: none"> • Fix the control lever • Confirm speed droop - adjust using screw (3) • Confirm
Boost Compensator System		-	-	-	<ul style="list-style-type: none"> • Fix the control lever • Adjust using screw (6) • Confirm the boost compensator stroke is: (mm)
Idling Adjustment		750+37 +30	7.8 -0.5	-	<ul style="list-style-type: none"> • Fix the control lever • Adjust using spring capsule (5) • Confirm
1. Idling Sub Spring					
2. Control Lever	H	400	8.0	-	<ul style="list-style-type: none"> • Adjust using the control lever
Full-load Adjustment		850	10.6	-	<ul style="list-style-type: none"> • Confirm
Control Lever Angle Measurement		<ul style="list-style-type: none"> • Measure the control lever angle at the "idling" and "full" positions. • When the control lever is depressed toward the "full" position, replace the shifter's shim with a thicker one. • When the control lever is depressed toward the "idling" position, replace the shifter's shim with a thinner one. 			
Control Rack Limiter Adjustment		0	approx. 17.5	-	<ul style="list-style-type: none"> • Adjust using screw

A15

ZEXEL - Test values
Injection pumps



A16

ZEXEL - Test values
Injection pumps



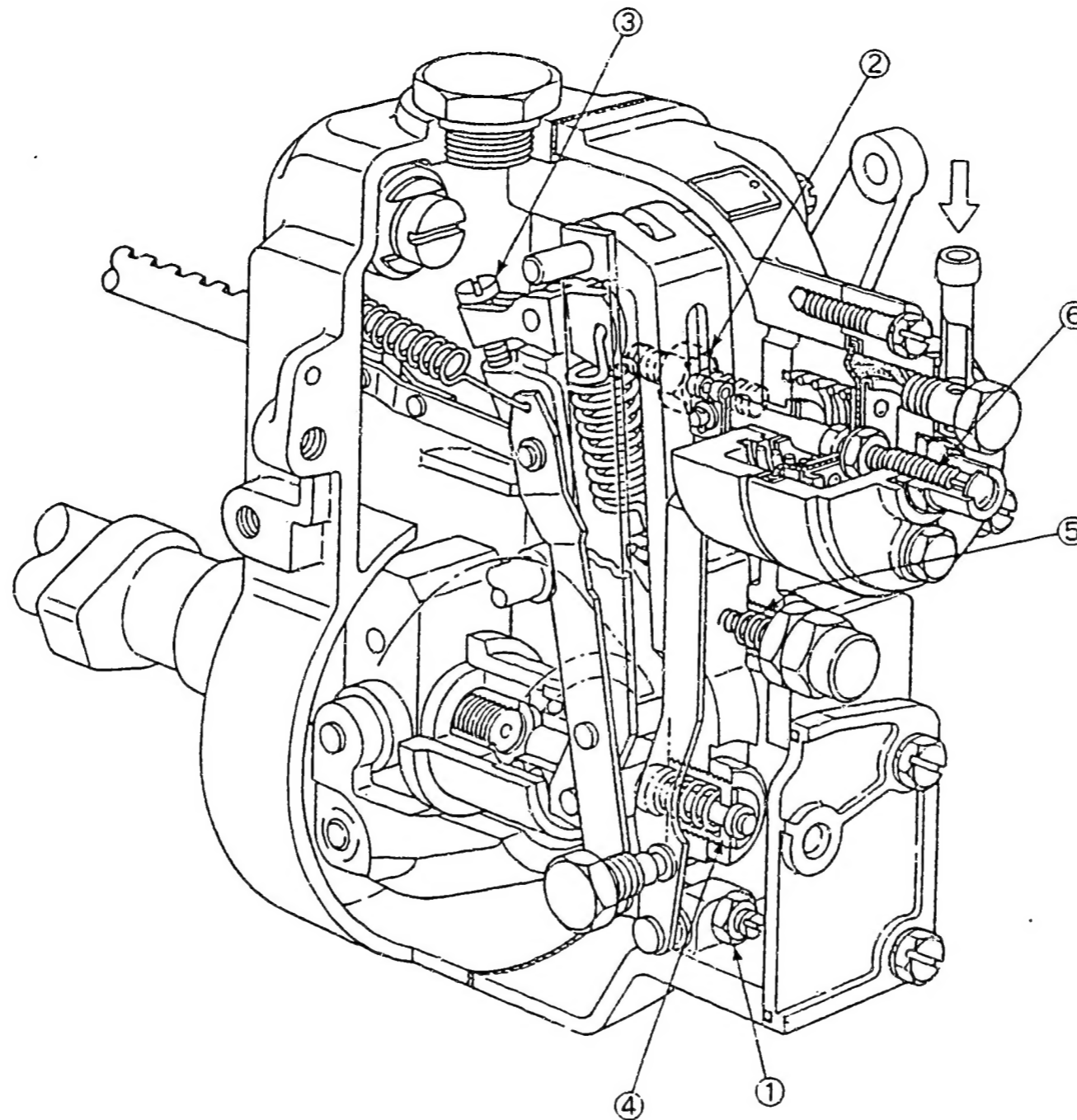

Figure 78

- 1 = Screw
- 2 = Screw
- 3 = Screw
- 4 = Spring capsule
- 5 = Spring capsule
- 6 = Screw

A17

ZEXEL - Test values
Injection pumps



A18

ZEXEL - Test values
Injection pumps



ZEXEL - TEST VALUES
Injection pumps

BOSCH No.	:	9 400 610 223	1/4
ZEXEL No.	:	103662-2292	
Date	:	31.10.1992	[6]
Company	:	KOMATSU	
Engine	:	SA6D170A / 6162-73-1332	

IP-Type number : 103066-3760 / PE6ZW
Governor type number : 105445-0521 / EP/RSUV

TEST PREREQUISITES

Test oil : ISO-4113
Test oil inlet temperature °C : 40.00...45.00
Inlet pressure bar : 1.6
Test nozzle holder combination : 0 681 343 002
Opening pressure bar : 175
Test pressure line
Inner x Outer Dia - Length mm : 4.00 x 8.00 x 1500

PORT CLOSING

Prestroke mm : 3.8 ± 0.05
Rod position mm : -
Port closing mark Cyl. No. : -
Cam sequence : 1-5-3-6-2-4

Port closing mark Cyl. No. : -
Port closing difference °NW : 0-60-120-180-240-300

Tolerance +- °C: 0.50 (0.75)



Continued (Test values)

Injection Quantity :

Adjusting Point	Rack Pos. (mm)	P. Speed (rpm)	Injection Q'ty (cm ³ /1000 str.)	Difference (%)	Fixed	Remarks
A	18.4	875	584 ± 5	± 4.0	Rack	Basic
H	approx. 7.8	400	75.7 ± 5	± 14.0	Rack	
A	18.4	875	584 ± 5	-	Lever	Basic

Timing Advance Specification :

Pump Speed (rpm)						
Advance Angle (deg)						

A20

ZEXEL - Test values
Injection pumps



A21

ZEXEL - Test values
Injection pumps



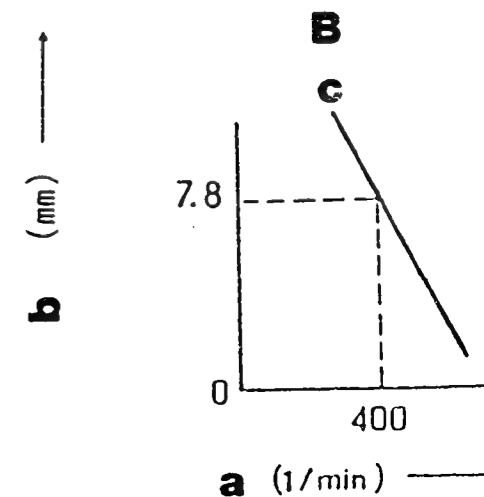
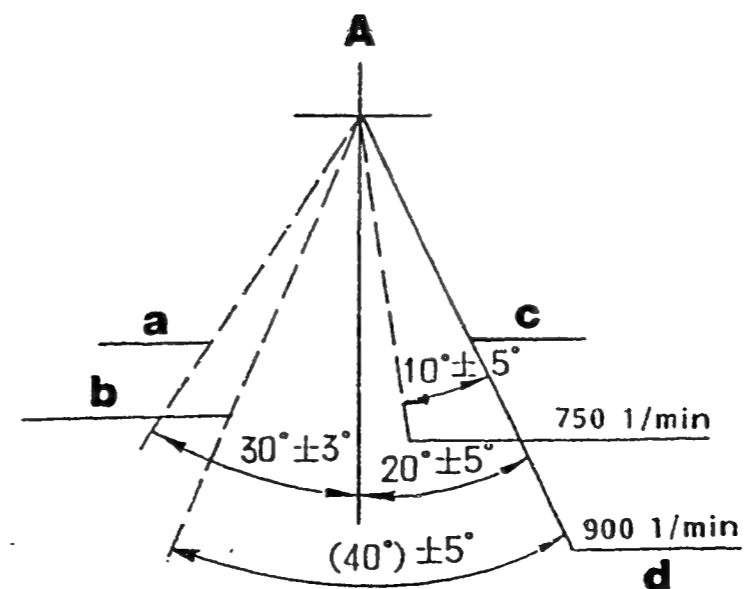
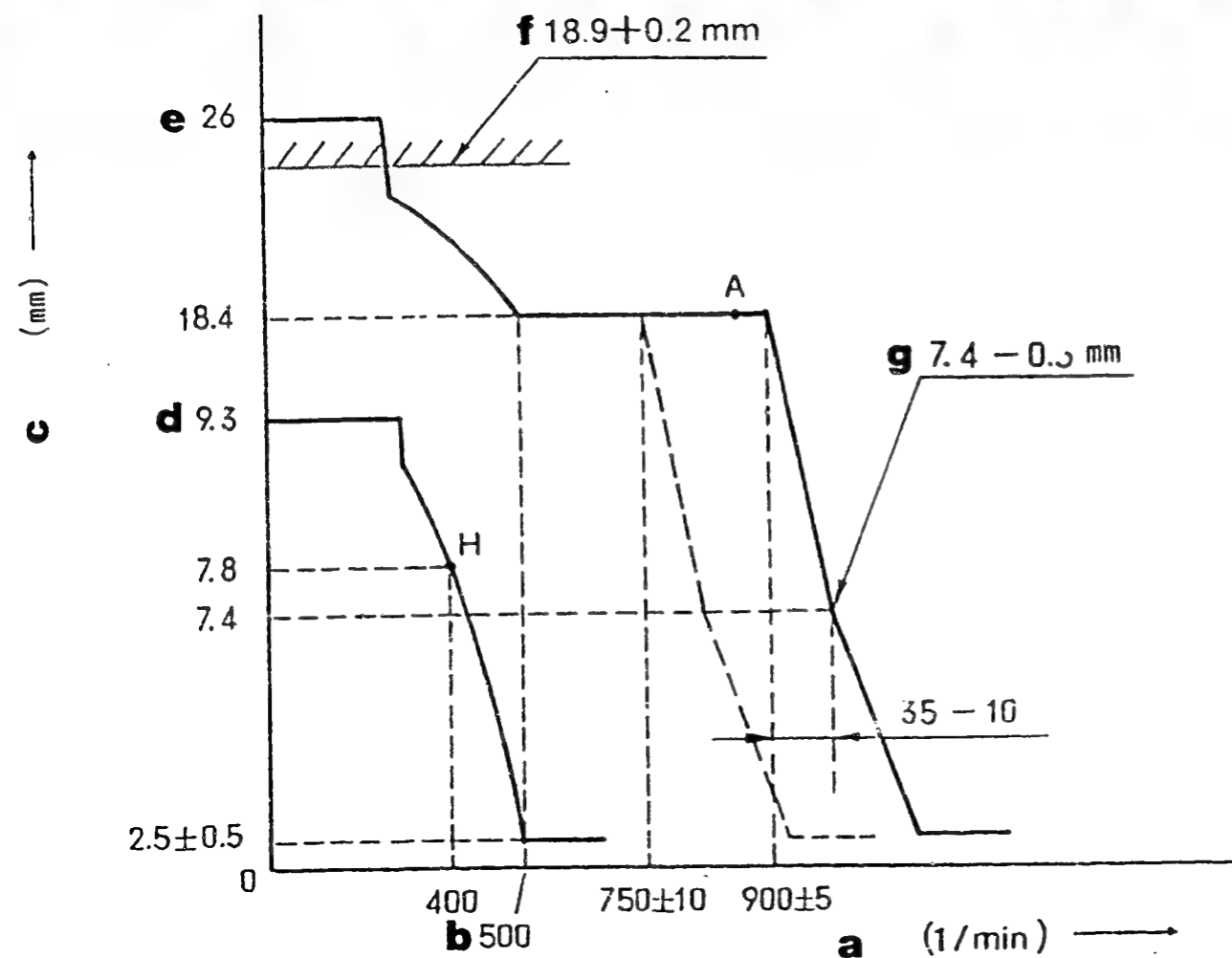

Figure 79

GOVERNOR ADJUSTMENT

103662-2292 2/4

Recommended speed droop adjustment screw position: 10

Minimum-Maximum Speed Specification

- a = Pump speed
- b = Above
- c = Control rack position
- d = Above
- e = Above
- f = Control rack limit:
- g = Idle-sub spring setting:

A = Speed Control Lever Angle

- a = Stop
- b = Idling
- c = Full-speed
- d = (On our shipment)

B = Variable Speed Specification

- a = Pump speed
- b = Control rack position
- c = Idle setting

A22

ZEXEL - Test values
Injection pumps



A23

ZEXEL - Test values
Injection pumps



■ Note

- Before adjustment, remove the idling sub spring.
- Move the control lever fully in the stop direction, and set the minimum-speed stopper bolt so that the control rack position is 0.5 - 1.0 mm.

■ ADJUSTMENT

		Pump Speed (rpm)	Rack Position (mm)	Boost pressure kPa (mmHg)	Remarks
Full-load Adjustment (Temporary)		1100 600	18.4 18.4	-	<ul style="list-style-type: none"> • Adjust using screw (2) • Adjust using screw (1)
Torque Control Spring Adjust- ment	1.st stroke	above 500	18.4	-	<ul style="list-style-type: none"> • Adjust using spring capsule (4) • Confirm • Confirm the torque control stroke is: (mm)
	2.st stroke	-	-	-	<ul style="list-style-type: none"> • Adjust using spring capsule (4) • Confirm • Confirm the torque control stroke is: (mm)
Maximum-speed Adjustment		900 ± 5 900+35 +25	18.4 7.4	-	<ul style="list-style-type: none"> • Fix the control lever • Confirm speed droop - adjust using screw (3) • Confirm
Boost Compensator System		-	-	-	<ul style="list-style-type: none"> • Fix the control lever • Adjust using screw (6) • Confirm the boost compensator stroke is: (mm)
Idling Adjustment 1. Idling Sub Spring		900 ± 5 900+35 +25	7.4	-	<ul style="list-style-type: none"> • Fix the control lever • Adjust using spring capsule (5) • Confirm
2. Control Lever		0 400 above 500	above 9.3 7.8 2.5 ± 0.5	-	<ul style="list-style-type: none"> • Adjust using the control lever • Confirm
Full-load Adjustment		875	18.4	-	<ul style="list-style-type: none"> • Confirm
Control Lever Angle Measurement		<ul style="list-style-type: none"> • Measure the control lever angle at the "idling" and "full" positions. • When the control lever is depressed toward the "full" position, replace the shifter's shim with a thicker one. • When the control lever is depressed toward the "idling" position, replace the shifter's shim with a thinner one. 			
Control Rack Limiter Adjustment		0	18.9 + 0.2	-	<ul style="list-style-type: none"> • Adjust using screw

A24

ZEXEL - Test values
Injection pumps



A25

ZEXEL - Test values
Injection pumps



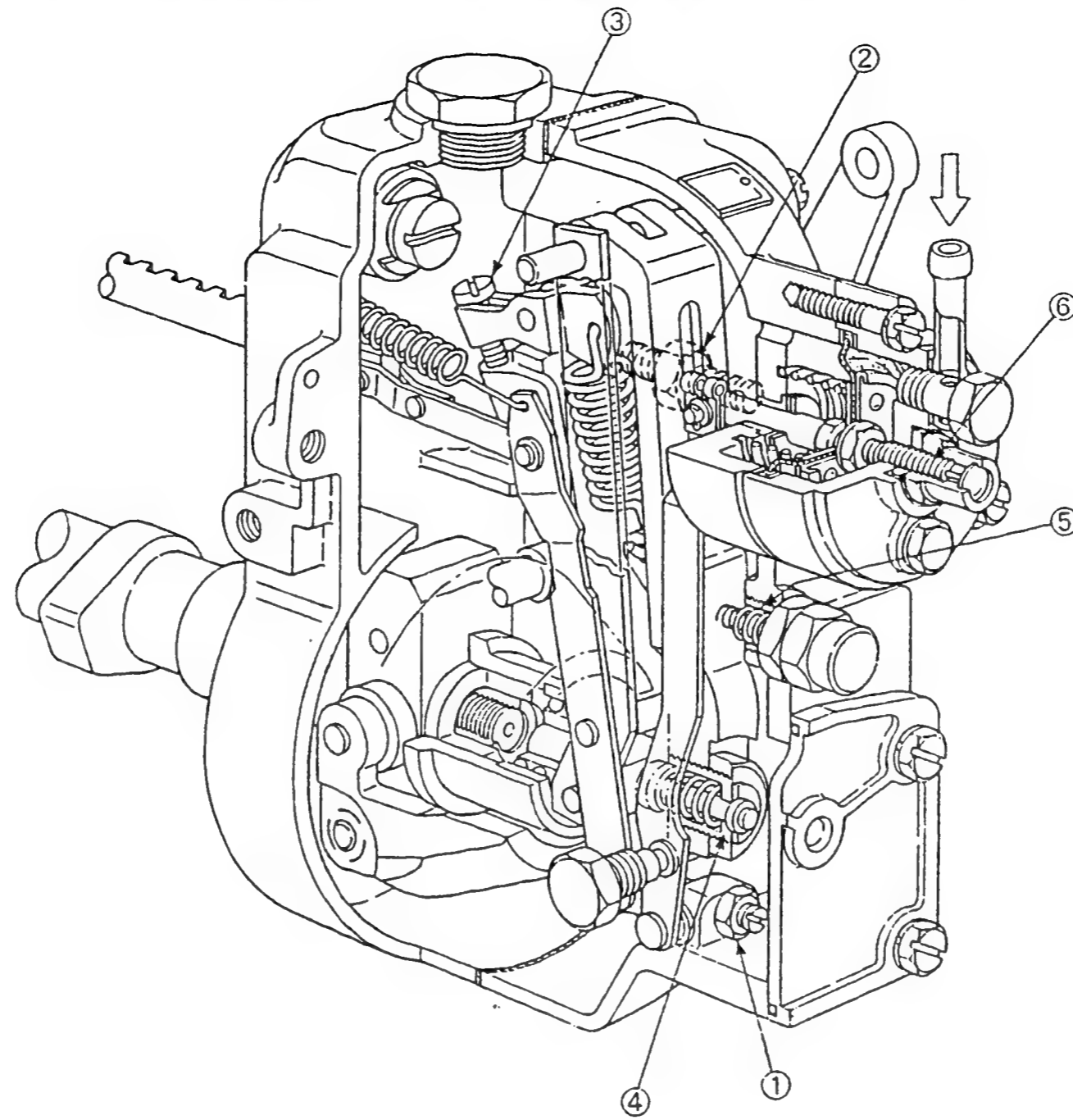

Figure 80

- 1 = Screw
- 2 = Screw
- 3 = Screw
- 4 = Spring capsule
- 5 = Spring capsule
- 6 = Screw

103662-2292 4/4

A26

ZEXEL - Test values
Injection pumps



A27

ZEXEL - Test values
Injection pumps



ZEXEL - TEST VALUES
Injection pumps

BOSCH No.	:	9 400 610 224	1/4
ZEXEL No.	:	103662-3051	
Date	:	31.10.1992	[6]
Company	:	KOMATSU	
Engine	:	SA6D170A / 6162-73-1334	

IP-Type number : 103066-3900 / PE6ZW
Governor type number : 105445-0791 / EP/RSUV

TEST PREREQUISITES

Test oil : ISO-4113
Test oil inlet temperature °C : 40.00...45.00
Inlet pressure bar : 1.6
Test nozzle holder combination : 0 681 343 002
Opening pressure bar : 175
Test pressure line
Inner x Outer Dia - Length mm : 4.00 x 8.00 x 1500

PORT CLOSING

Prestroke mm : 3.8 ± 0.05
Rod position mm : -
Port closing mark Cyl. No. : -
Cam sequence : 1-5-3-6-2-4

Port closing mark, Cyl. No. : -
Port closing difference °NW : 0-60-120-180-240-300

Tolerance +- °C: 0.50 (0.75)

B1

ZEXEL - Test values

Injection pumps



Injection Quantity :

Adjusting Point	Rack Pos. (mm)	P. Speed (rpm)	Injection Q'ty (cm ³ /1000 str.)	Difference (%)	Fixed	Remarks
A	18.4	875	584.0 ± 5.0	± 4.0	Lever	Basic
H	approx. 7.8	400	75.7 ± 5.0	± 14.0	Rack	
A	18.4	875	584.0 ± 5.0	-	Lever	Basic

Timing Advance Specification :

Pump Speed (rpm)						
Advance Angle (deg)						

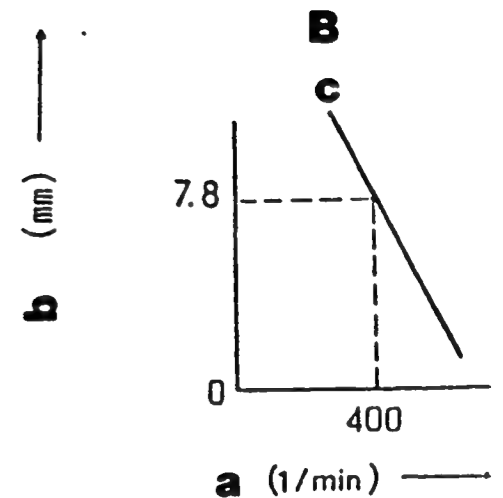
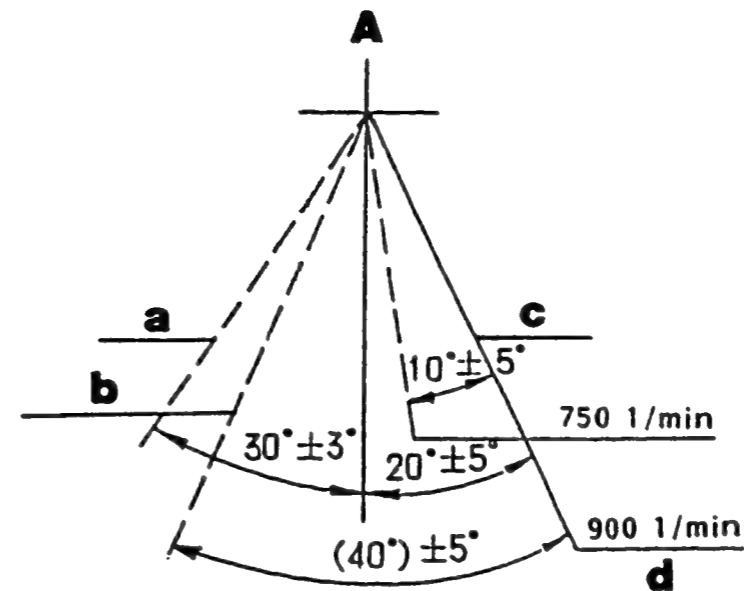
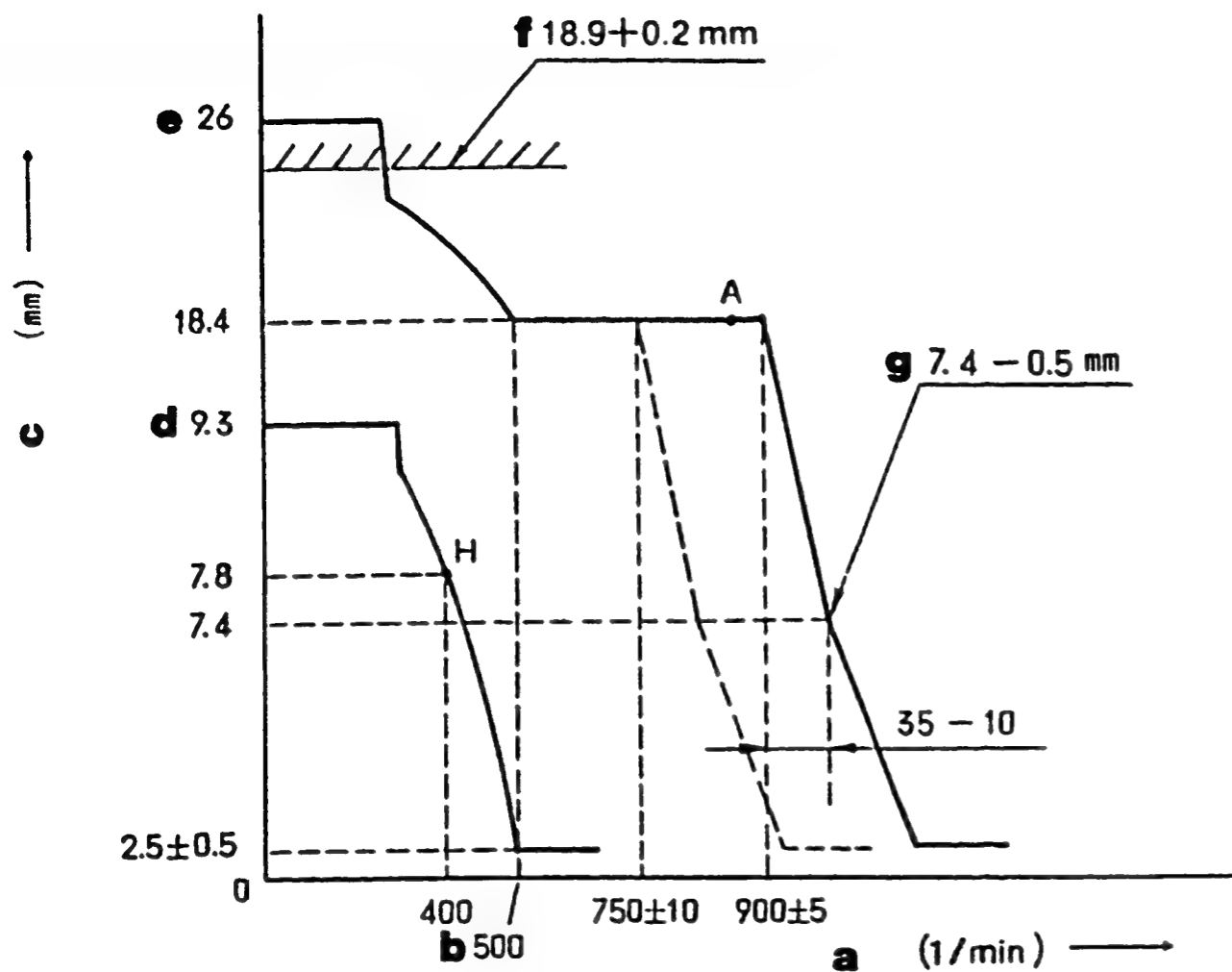

Figure 81

GOVERNOR ADJUSTMENT

Recommended speed droop adjustment screw position: 10

103662-3051 2/4

Minimum-Maximum Speed Specification

- a = Pump speed
- b = Above
- c = Control rack position
- d = Above
- e = Above
- f = Control rack limit:
- g = Idle-sub spring setting:

A = Speed Control Lever Angle

- a = Stop
- b = Idling
- c = Full-speed
- d = (on our shipment)

B = Variable Speed Specification

- a = Pump speed
- b = Control rack position
- c = Idle setting

B4

ZEXEL - Test values
Injection pumps



B5

ZEXEL - Test values
Injection pumps



		Pump Speed (rpm)	Rack Position (mm)	Boost pressure kPa (mmHg)	Remarks
Full-load Adjustment (Temporary)		1100 600	18.4 18.4	-	<ul style="list-style-type: none"> Adjust using screw (2) Adjust using screw (1)
Torque Control Spring Adjust- ment	1.st stroke	above 500	18.4	-	<ul style="list-style-type: none"> Adjust using spring capsule (4) Confirm Confirm the torque control stroke is: (mm)
	2.st stroke	-	-	-	<ul style="list-style-type: none"> Adjust using spring capsule (4) Confirm Confirm the torque control stroke is: (mm)
Maximum-speed Adjustment		900 ± 5 900+35 +25	18.4 7.4	-	<ul style="list-style-type: none"> Fix the control lever Confirm speed droop - adjust using screw (3) Confirm
Boost Compensator System		-	-	-	<ul style="list-style-type: none"> Fix the control lever Adjust using screw (6) Confirm the boost compensator stroke is: (mm)
Idling Adjustment 1. Idling Sub Spring		900+35 +25	7.4	-	<ul style="list-style-type: none"> Fix the control lever Adjust using spring capsule (5) Confirm
2. Control Lever	H	0 400 above 500	above 9.3 7.8 2.5 ± 0.5	-	<ul style="list-style-type: none"> Adjust using the control lever Confirm
Full-load Adjustment		875	18.4	-	<ul style="list-style-type: none"> Confirm
Control Lever Angle Measurement		<ul style="list-style-type: none"> Measure the control lever angle at the "idling" and "full" positions. When the control lever is depressed toward the "full" position, replace the shifter's shim with a thicker one. When the control lever is depressed toward the "idling" position, replace the shifter's shim with a thinner one. 			
Control Rack Limiter Adjustment		0	18.9 + 0.2	-	<ul style="list-style-type: none"> Adjust using screw

B6

ZEXEL - Test values
Injection pumps



B7

ZEXEL - Test values
Injection pumps



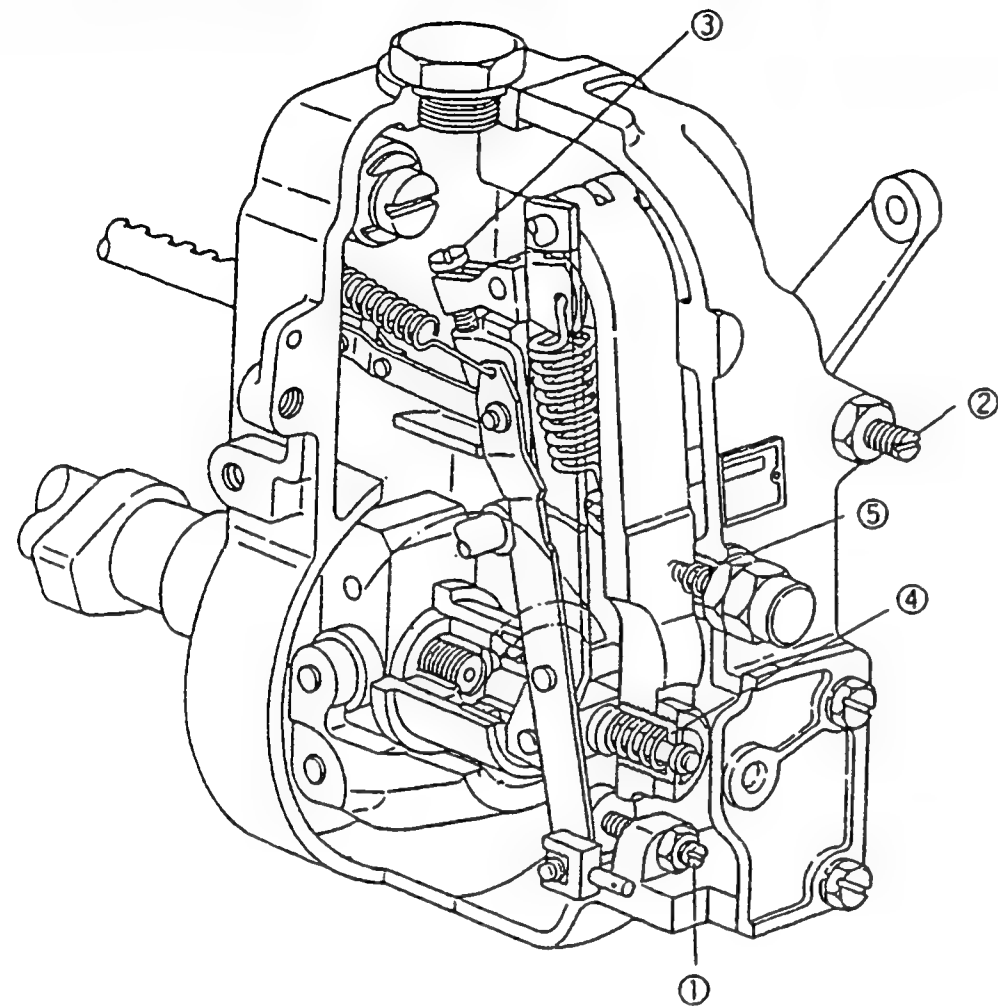
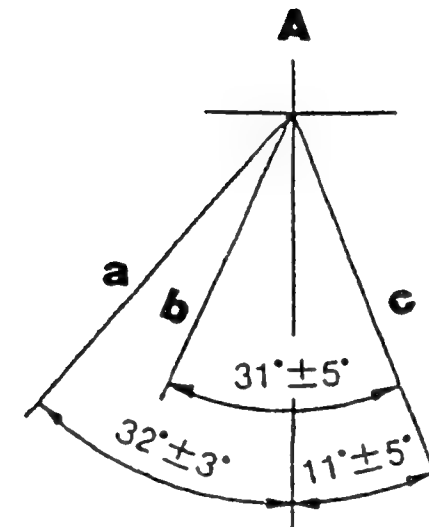

Figure 82

- 1 = Screw
- 2 = Screw
- 3 = Screw
- 4 = Spring capsule
- 5 = Spring capsule

■ Note

- Before adjustment, remove the idling sub spring.
- Move the control lever fully in the stop direction, and set the minimum-speed stopper bolt so that the control rack position is 0.5 - 1.0 mm.



A = CONTROL LEVER ANGLE

- a = Stop
- b = Idling
- c = Full-speed

103662-3051 4/4

B8

ZEXEL - Test values
Injection pumps



B9

ZEXEL - Test values
Injection pumps



Test oil ISO 4113 or SAE J967d	ZEXEL - TEST VALUES				1/2	
	Distributor pumps				BOSCH No. 9 460 610 336	
	Engine model: TD27				ZEXEL No. 104740-7680	
					Date: 31.10.1992 [2]	
					Company: NISSAN DIESEL	
					No. 16700 43G19	
Injection pump no.: 104640-9562	(NP-VE4/10F2150RNP558)					
Pump rot.: Clockwise-viewed from drive side	Test-nozzle holder combination: 1 688 901 000			Test pressure line: 1 680 750 017		
1. Setting values		P. Speed (rpm)	Setting values	Charge-air pressure kPa (mmHg)	Difference in delivery (cm ³)	
1-1	Timing device travel	1700	4.7 - 5.1 (mm)			
1-2	Supply pump pressure	1700	549-608 (5.6-6.2)kPa (kgf/cm ²)			
1-3	Full load delivery	1100	49.8 - 50.8 (cm ³ /1000st)		3.0	
	Full load delivery		(cm ³ /1000st)			
1-4	Idle speed regulation	350	5.3 - 9.3 (cm ³ /1000st)		2.0	
1-5	Start	100	45.0 - 80.0 (cm ³ /1000st)			
1-6	Full-load speed regulation	2350	32.2 - 36.2 (cm ³ /1000st)			
1-7	Load-timer adjustment					
2. Test values						
2-1	Timing device	N = rpm mm	1100 2.0-3.2	1700 4.6-5.2	2150 6.0-7.2	2550 6.8-7.8
2-2	Supply pump	N = rpm kPa (kgf/cm ²)		1700 549-608 (5.6-6.2)	2150 647-706 (6.6-7.2)	
2-3	Overflow delivery	N = rpm cm ³ /10s	1100 43.0-87.0			
2-4 Fuel injection quantities						
	Speed control lever pos.	P. Speed (rpm)	Fuel delivery (cm ³ /1000st)	Charge-air pres kPa (mmHg)	Difference in delivery (cm ³)	
	End stop	1100	49.3 - 51.3			
		600	48.8 - 52.8			
		2150	38.7 - 42.9			
		2350	31.7 - 36.7			
		2550	5.6 - 14.6			
		2700	below 5.0			
	Switch off	350	0			
	Idle- stop	350	5.3 - 9.3			
		450	below 3.0			
2-5	Solenoid	Cut-in voltage max.:8V Test voltage: 12 - 14V				
3. Dimensions						
K	3.2 - 3.4 mm					
KF	5.7 - 5.9 mm					
MS	0.8 - 1.0 mm					
BCS	- mm					
Pre-st.	- mm					
Control lever angle						
α	51.5°- 59.5°deg					
Ya	26.3 - 28.7 mm					
β	31°- 41° deg					
B	9.3 - 12.9 mm					
γ	- deg					
C	- mm					

B10

ZEXEL - Test values
Injection pumps

B11

ZEXEL - Test values
Injection pumps

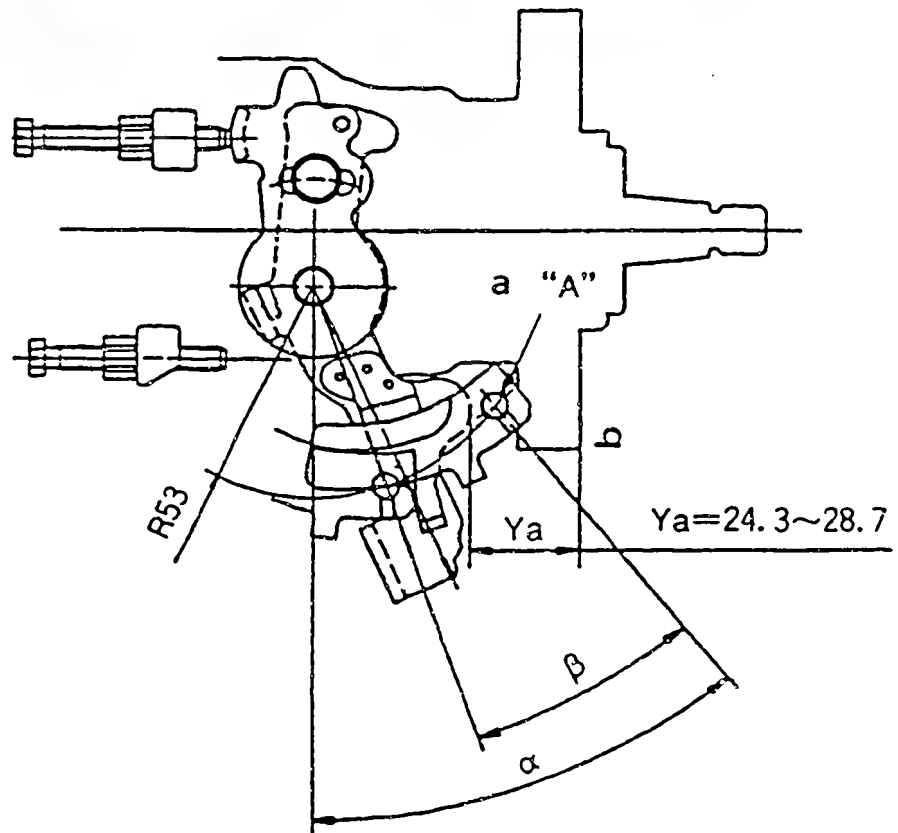

Figure 83

104740-7680 2/2

a = Hole
b = Flange

■ Control Lever Angle Measurement Position

1. Measure the control lever angles (α , β , γ) at hole „A”.

B12

ZEXEL - Test values

Injection pumps



Test oil:
ISO 4113 or
SAE J967d

ZEXEL - VALUES
Distributors pumps
Engine model: 4D56-T

BOSCH No. 9 460 610 523
ZEXEL No. 104740-8182
Date: 31.10.1992 [0]
Company: MITSUBISHI
No. MD167348

Injection pump no.: 104640-8182 (NP-VE4/10F2100RNP952)

Pump rot.: Clockwise-viewed from drive side
Test-nozzle holder combination: 1 688 901 022
Test pressure line: 1 680 750 073

1. Setting values		P. Speed (rpm)	Setting values	Charge air pressure kPa (mmHg)	Difference in delivery (cm³)
1-1	Timing device travel	1000	3.5 - 3.9 (mm)	72.0-74.6 (540-560)	
1-2	Supply pump pressure	1000	382-441 (3.9-4.5) kPa (kgf/cm²)	72.0-74.6 (540-560)	
1-3	Full load delivery	2000 (FULL)	64.6 - 65.6 (cm³1000st)	72.0-74.6 (540-560)	5.0
	Full load delivery	750 (BCS)	63.4 - 64.4 (cm³1000st)	42.7-45.3 (320-340)	
1-4	Idle speed regulation	375	14.9 - 17.9 (cm³1000st)	0	2.5
1-5	Start	100	67.0 - 87.0 (cm³1000st)	0	
1-6	Full-load speed regulation	2650	24.9 - 30.9 (cm³1000st)	72.0-74.6 (540-560)	5.5
1-7	Load timer adjustment	1000	T-0.5-0.9 (mm)	72.0-74.6 (540-560)	

2. Test values

	C. air pres	72.0-74.6 (540-560) mmHg					
2-1 Timing device	N = rpm mm	500 0.7-2.3	1000 3.4-4.0	1250 4.1-5.3	1500 5.1-6.3	2000 7.2-8-4	2100 7.3-8.2
2-2 Supply pump	N = rpm kPa (kgf/cm²)		1000 382-441 (3.9-4.5)		1500 500-559 (5.1-5.7)		2100 637-696 (6.5-7.1)
2-3 Overflow delivery	N = rpm cm³/10s		1000 48.0-92.0				

2-4 Fuel injection quantities

Control lever position	P. Speed (rpm)	Fuel delivery (cm³/1000st)	Charge-air pressure kPa (mmHg)	Difference in delivery (cm³)
End stop	2000 (FULL)	64.1 - 66.1	72.0-74.6 (540-560)	
	750 (BCS)	62.9 - 64.9	42.7-45.3 (320-340)	
	600	46.0 - 51.0	0	
	1250	68.2 - 73.2	72.0-74.6 (540-560)	
	2100	62.5 - 65.5	72.0-74.6 (540-560)	
	2650	24.4 - 31.4	72.0-74.6 (540-560)	
	*1 2950	below 5.0	72.0-74.6 (540-560)	
Switch off	375	0	0	
Idle stop	750	below 3.0	0	
	375	14.4 - 18.4	0	
Partial load	*2 900	7.5 - 19.5	0	

2-5 Solenoid
Cut-in voltage max.: 8V
Test voltage: 12 - 14V

3. Dimensions

K 3.2 - 3.4 mm
KF 5.7 - 5.9 mm
MS 0.6 - 0.8 mm
BCS - mm
Full st. - mm

Control lever angle

α 55° - 63° deg
A 8.3 - 14.8 mm
β 37° - 47° deg
B 11.7 - 15.3 mm
γ - deg
C - mm



1. Adjustment

1) Fix the control lever in the position satisfying the following conditions:

Boost Pressure: 72.0 - 75.0 kPa (640-660) mmHg
 Pump Speed : 1000 rpm
 Fuel Injection: 49.5 - 51.0 cm³/1000st
 Quantity

2) With the control lever positioned as described in 1) above, adjust the governor sleeve so that the Timer Stroke conforms to the specified values (Item 1-7).

2. Confirmation of Timer Characteristics

Fix the control lever in the position satisfying the following conditions, and confirm the Timer Stroke.

Control lever position			Specified values	
Pump speed (rpm)	Fuel injection quantity (cm ³ /1000st)	Boost press. kPa (mmHg)	Timer stroke (mm)	Timer stroke reduction value (mm)
1000	49.0 - 51.0	72.0-75.0 (540-560)	-	0.4 - 1.0
1000	38.5 - 41.5	72.0-75.0 (540-560)	-	1.2 - 2.4

Note:

- For items *, confirmation is as follows:
 1. Insert the shims (1 mm thick) between the control lever and the full-speed stopper bolt.
 2. Confirm the fuel injection quantity at the specified pump speed.
- Insert an 8.9 mm partial characteristics shim (for V-actuator adjustment) and measure the fuel injection quantity (for items marked *2).

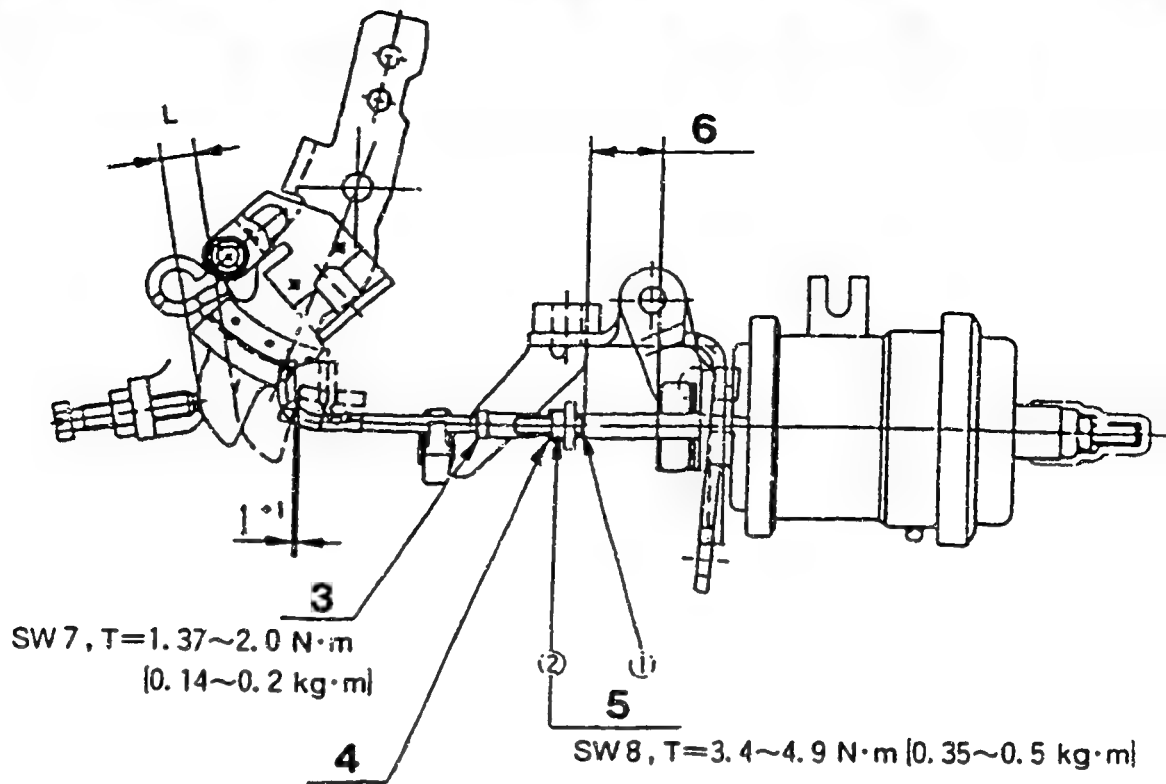

Figure 84

104740-8182 3/4

- 3 = Rod position adjusting nut
- 4 = Rod position adjusting nut
- 5 = Stroke adjusting nut
- 6 = Actuator stroke

■ 2-STAGE ACTUATOR ADJUSTMENT SPECIFICATIONS

Actuator Adjustment

1. Attach the actuator to the injection pump.
2. Move the control lever to the idle position.



(Continued)

3. Adjust the rod position adjusting nut so that the clearance between the control lever and rod is $i+1$ mm.
4. Insert a shim of thickness L mm (determined from the partial injection quantities graph) between the control lever and the idle stopper.
5. Adjust the screw (1) so that a full actuator stroke is obtained at the above control lever angle. Then, fix the screw using the nut (2).

B18

ZEXEL - Test values

Injection pumps



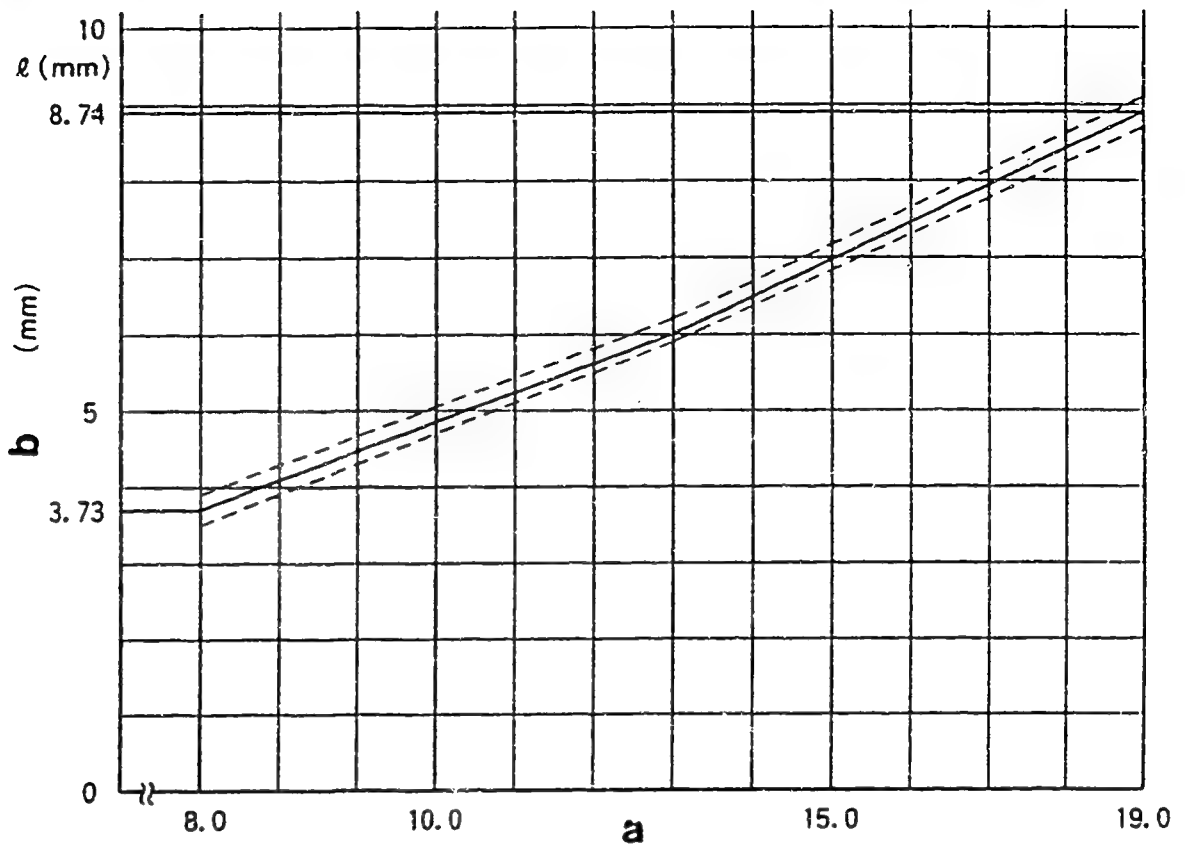

Figure 85

104740-8182 4/4

a = Fuel injection quantity (cm³/1000st)
 b = Shim thickness

Graph of actuator stroke adjusting shim thickness for partial fuel injection quantities.

At NP = 900 rpm, insert an 8.9 mm shim between the control lever and the idle stopper and measure the fuel injection quantity.



Actuator stroke adjustment points (for reference)

Injection quantity specification		Actuator stroke set position		
Pump speed (rpm)	Injection quantity (cm ³ /1000st)	Control lever angle	Shim thickness l (mm)	Actuator stroke (mm)
900	7.7 ± 1	(9.5°)		approx. 9.6

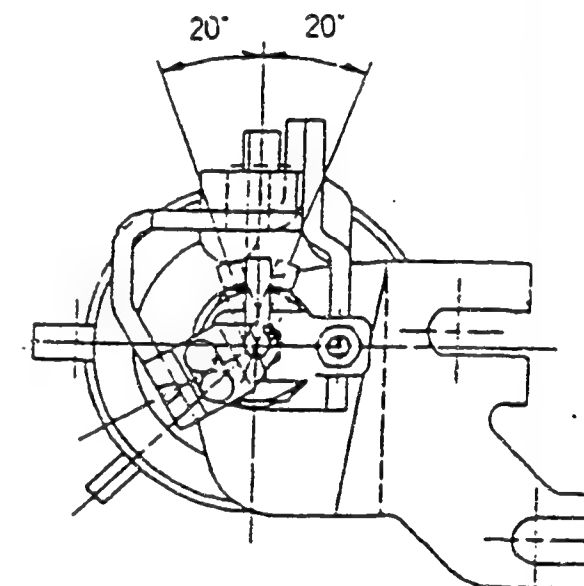

Figure 86

2-stage actuator adjustment specifications

Rod installation position tolerance ± 20°



Test oil
ISO 4113 od
SAE J967d

ZEXEL - TEST VALUES
Distributor pumps
Engine model: 4D56

1/2

BOSCH No. 9 460 610 537
ZEXEL No. 104740-8431
Date: 31.10.1992 [2]
Company: MITSUBISHI
No. MD183698

Injection pump no.: 104640-8431 (NP-VE4/10F2000RNP1049)

Pump rot.: Clockwise-viewed from drive side
Test-nozzle holder combination: 1 688 901 000
Test pressure line: 1 680 750 017

1. Setting values		P. Speed (rpm)	Setting values	Charge-air pressure kPa (mmHg)	Difference in delivery (cm ³)
1-1	Timing device travel	1250	4.3 - 4.7 (mm)		
1-2	Supply pump pressure	1250	451-490 (4.6-5.0) kPa (kgf/cm ²)		
1-3	Full load delivery	1250	43.3 - 44.3 (cm ³ /1000st)		3.0
	Full load delivery		- (cm ³ /1000st)		
1-4	Idle speed regulation	375	8.5 - 11.5 (cm ³ /1000st)		2.0
1-5	Start	100	63.0 - 83.0 (cm ³ /1000st)		
1-6	Full-load speed regulation	2150	15.1 - 21.1 (cm ³ /1000st)		4.0
1-7	Load-timer adjustment	1250	T-0.8-1.2 (mm)		
1-8					

2. Test values

2-1 Timing device	N = rpm mm	500 1.4-2.6	750 2.2-3.4	1250 4.2-4.8	1750 6.0-7.2	2000 7.1-8.0
2-2 Supply pump	N = rpm kPa (kgf/cm ²)			1250 451-490 (4.6-5.0)		2000 618-677 (6.3-6.9)
2-3 Overflow delivery	N = rpm cm ³ /10s			1250 48.0-92.0		

2-4 Fuel injection quantities

Speed control lever pos.	Pump speed (rpm)	Fuel delivery (cm ³ /1000st)	Charge-air press. kPa (mmHg)	Difference (cm ³)
End stop	1250	42.8 - 44.8		
	600	40.3 - 44.3		
	1750	36.2 - 40.2		
	2000	35.1 - 39.3		
	2150	14.6 - 21.6		
	2500	above 5.0		
Switch off	375	0		
Idle-stop	750	below 3.0		
	600	below 5.0		
	375	8.0 - 12.0		

2-5 Solenoid
Cut-in voltage max. 8 V
Test voltage: 12 - 14 V

3. Dimensions

K 3.2 - 3.4 mm
KF 5.7 - 5.9 mm
MS 1.1 - 1.3 mm
BCS - mm
Prestr. - mm

Control lever angle

α 55° - 63° deg
A 10.9 - 16.0 mm
 β 40° - 50° deg
B 12.7 - 16.3 mm
 γ - deg
C - mm

B22

ZEXEL - Test values
Injection pumps



B23

ZEXEL - Test values
Injection pumps



1. Adjustment

1) Fix the control lever in the position satisfying the following conditions:

Boost Pressure: - kPa (mmHg)
 Pump Speed : 1250 rpm
 Fuel Injection
 Quantity : 35.2 - 36.2 cm³/1000st

2) With the control lever positioned as described in 1) above, adjust the governor sleeve so that the Timer Stroke conforms to the specified values (item 1-7).

Control lever position			Specified values	
Pump speed (rpm)	Fuel injection quantity (cm ³ /1000st)	Boost pressure kPa (mmHg)	Timer stroke (mm)	Timer stroke reduction value (mm)
1250	34.7 - 36.7	-	-	0.7 - 1.3
1250	26.7 - 29.7	-	-	1.8 - 2.4

Test oil
ISO 4113 or
SAE J967d

ZEXEL - TEST VALUES
Distributor pumps
Engine model: TD27

1/3

BOSCH No.	9 460 610 538
ZEXEL No.	104740-9573
Date:	31.10.1992 [1]
Company:	NISSAN DIESEL
No.	16700 43G20

Injection pump no.: 104640-9572 (NP-VE4/10F2150RNP559)

Pump rot.: Clockwise-viewed from drive side
Test-nozzle holder combination: 1 688 901 000
Test pressure line: 1 680 750 017

1. Setting values	P. Speed (rpm)	Setting values	Charge-air pressure kPa (mmHg)	Difference in delivery (cm ³)
1-1 Timing device travel	1700	4.7 - 5.1 (mm)		
1-2 Supply pump pressure	1700	549-608 (5.6-6.2) kPa (kgf/cm ²)		
1-3 Full load delivery	1100	49.8 - 50.8 (cm ³ /1000st)		3.0
Full load delivery		(cm ³ /1000st)		
1-4 Idle speed regulation	350	5.3 - 9.3 (cm ³ /1000st)		2.0
1-5 Start	100	45.0 - 80.0 (cm ³ /1000st)		
1-6 Full-load speed regulation	2350	32.2 - 36.2 (cm ³ /1000st)		
1-7 ACS adjustment	1100	39.7 - 42.7 (cm ³ /1000st)	-21.9±0.7 (-164±5)	

2. Test values

2-1 Timing device	N = rpm mm	1100 2.2-3.0	1700 4.6-5.1	2150 6.0-7.2	2550 6.8-7.8
2-2 Supply pump	N = rpm kPa (kgf/cm ²)		1700 549-608 (5.6-6.2)	2150 647-706 (6.6-7.2)	
2-3 Overflow delivery	N = rpm cm ³ /10s	1100 43.0-87.0			
2-4 Fuel injection quantities					
Speed control lever pos.	P. Speed (rpm)	Fuel delivery (cm ³ /1000st)	Charge-air press kPa (mmHg)	Difference deliv. (cm ³)	
End stop	1100	49.3 - 51.3	-21.9±0.7 (-164±5)		
	600	48.8 - 52.8			
	1100	39.2 - 43.2			
	2150	38.7 - 42.9			
	2350	31.7 - 36.7			
	2550	5.6 - 14.6			
	2700	below 5.0			
Switch off	350	0			
Idle-stop	450	below 3.0			
	350	5.3 - 9.3			
2-5 Solenoid	Cut-in voltage max.: 8V Test voltage: 12 - 14V				

3. Dimensions

K	3.2 - 3.4 mm
KF	5.7 - 5.9 mm
MS	0.8 - 1.0 mm
BCS	- mm
Pre-st.	- mm
Control lever angle	
α	51.5° - 59.5° deg
Ya	24.3 - 28.7 mm
β	31° - 41° deg
B	9.3 - 12.9 mm
γ	- deg
C	- mm

C1

ZEXEL - Test values
Injection pumps



C2

ZEXEL - Test values
Injection pumps



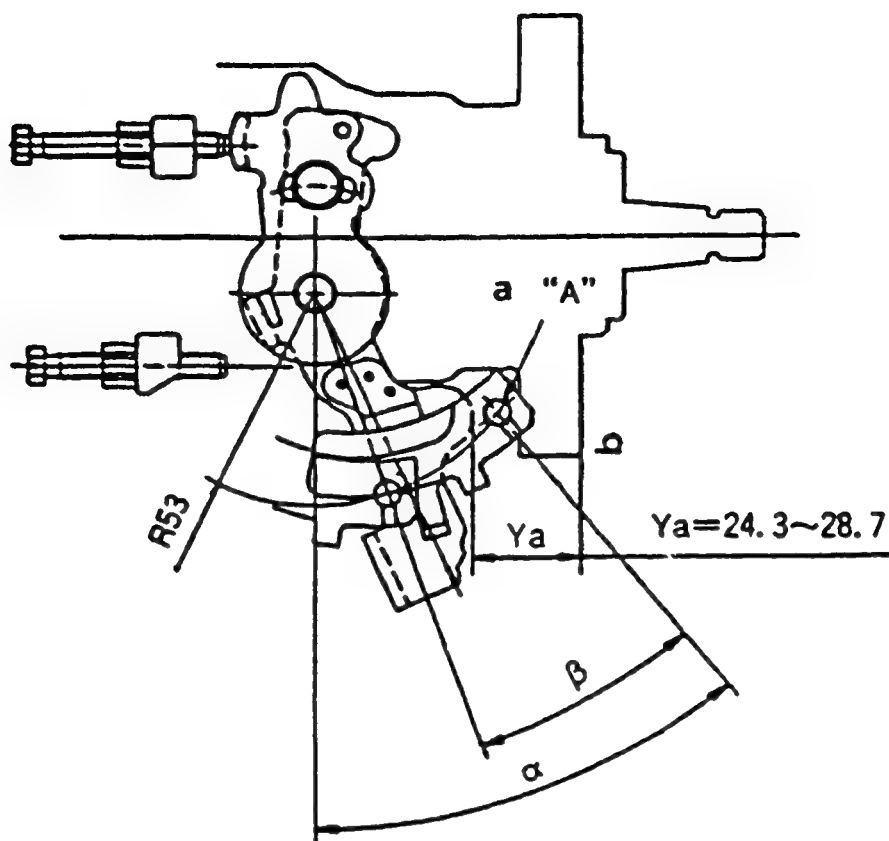

Figure 87

104740-9573 2/3

a = Hole
b = Flange

■ CONTROL LEVER ANGLE MEASUREMENT POSITION

1. Measure the control lever angles (α , β , γ) at hole „A“.



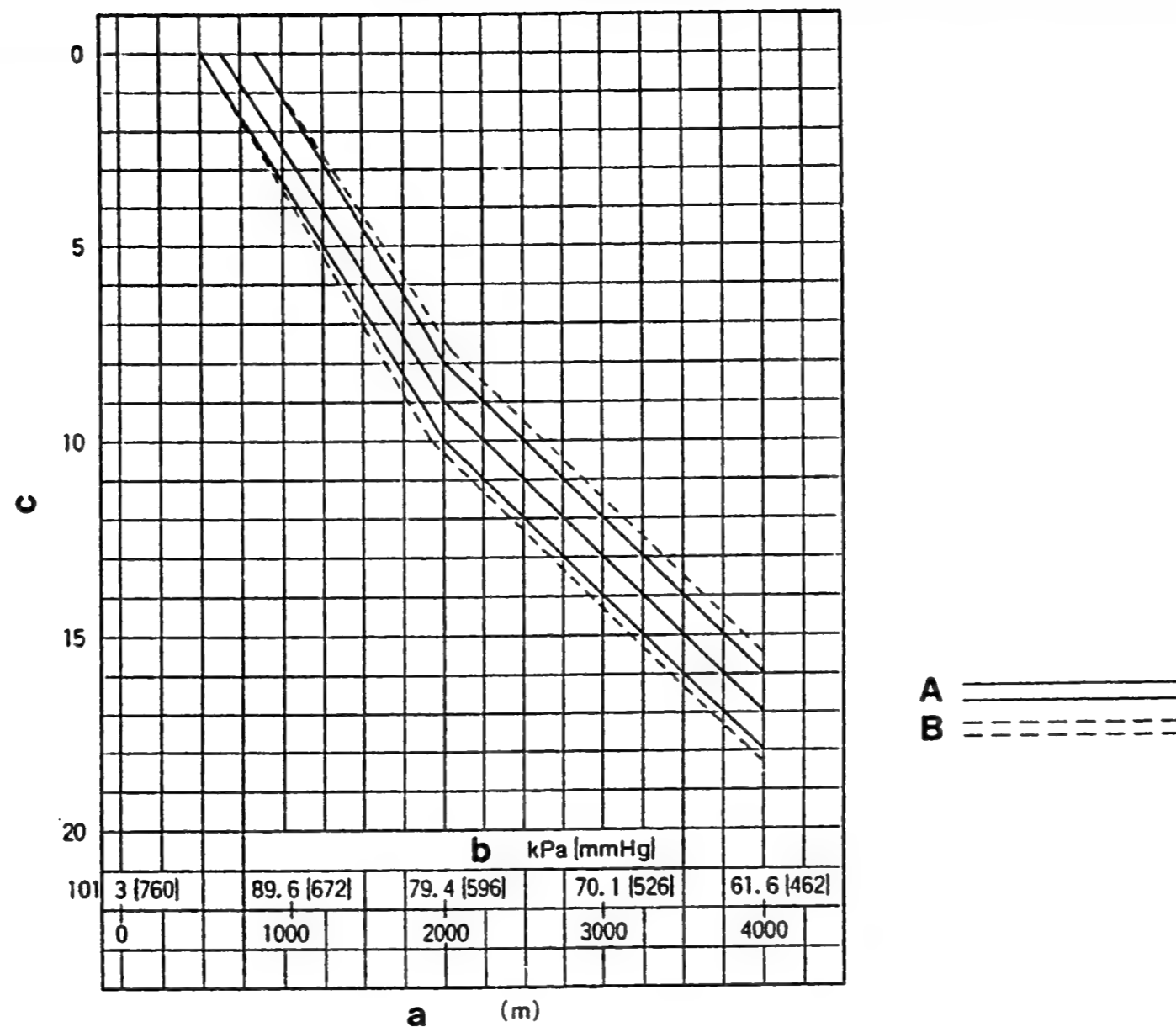

Figure 88

a = Altitude
 b = Atmospheric pressure
 c = Injection quantity decrease (cm³/1000st)

A = Adjustment value
 B = Inspection value

■ FULL-LOAD FUEL INJECTION QUANTITY AND ACS ADJUSTING PROCEDURE AT HIGH ALTITUDES

1. FULL-LOAD FUEL INJECTION QUANTITY ADJUSTMENT

- 1) Remove the ACS cover, the bellows and the adjusting shims.
- 2) Perform all adjustments as described in the adjusting specifications, except for ACS adjustment.

2. ACS ADJUSTMENT

- 1) Attach the ACS cover, the bellows and the adjusting shims.
- 2) At a pump speed of 1100 rpm and referring to the graph above, use the shims to adjust the fuel injection quantity decrease according to the altitude.

C4 ZEXEL - Test values
 Injection pumps

C5 ZEXEL - Test values
 Injection pumps

- Adjust the pump with the magnet valve OFF.

C8

ZEXEL - Test values

Injection pumps



Test oil:
ISO 4113 or
SAE J967d

ZEXEL - TEST VALUES
Distributor pumps
Engine model: CD17

1/4

BOSCH No.	9 460 610 533
ZEXEL No.	104748-2381
Date:	31.10.1992 [0]
Company:	NISSAN
No.	16700 16A68

Injection pump no.: 104648-2181 (NP-VE4/8F2500LNP164)

Pump rotation: Counter clockwise viewed from drive side	Test-nozzle holder combination: 1 688 901 000	Test pressure line: 1 680 750 017
---	--	--------------------------------------

1. Setting values		P. Speed (rpm)	Setting values	Charge air pressure kPa (mmHg)	Difference in delivery (cm ³)
1-1	Timing device travel	1200	1.8 - 2.4 (mm)		
1-2	Supply pump pressure	1200	304-363 (3.1-3.7) kPa (kgf/cm ²)		
1-3	Full load delivery	1200	29.5 - 30.5 (cm ³ /1000st)		2.5
	Full load delivery		(cm ³ /1000st)		
1-4	Idle speed regulation	400	8.3 - 11.3 (cm ³ /1000st)		3.0
1-5	Start	100	45.3 - 55.3 (cm ³ /1000st)		
1-6	Full-load speed regulation	2700	11.9 - 17.9 (cm ³ /1000st)		
1-7	Load-timer adjustment				
1-8					

2. Test values

2-1 Timing device	N = rpm	1200	1800	2500
	mm	1.7 - 2.5	4.0 - 5.2	6.8 - 8.0
2-2 Supply pump	N = rpm	1200	1800	2500
	kPa (kgf/cm ²)	294 - 373 (3.0 - 3.8)	431 - 510 (4.4 - 5.2)	598 - 677 (6.1 - 6.9)
2-3 Overflow delivery	N = rpm	1200		
	cm ³ /10s	36.0 - 80.0		

2-4 Fuel injection quantities

Control lever position	Pump Speed (rpm)	Fuel delivery (cm ³ /1000 strokes)	Charge air pressure kPa (mmHg)
End stop	1200	29.0 - 31.0	
	600	24.8 - 28.8	
	2500	26.7 - 30.7	
	2700	11.4 - 18.4	
	2900	below 6.0	
Switch off	400	0	
Idle stop	400	7.8 - 11.8	
	600	below 3.0	
Partial load	700	13.3 - 20.0	

2-5 Solenoid
Cut-in voltage max. 8 V
Test voltage: 12 - 14 V

3. Dimensions

K	3.2 - 3.4 mm
KF	5.7 - 5.9 mm
MS	1.7 - 1.9 mm
BCS	- mm
Pre-str.	- mm

Control lever angle

α	1° - 1° deg
Ya	15.4 - 18.1 mm
β	37° - 47° deg
B	10.7 - 14.8 mm
γ	10.5° - 11.5° deg
C	6.7 - 7.3 mm

C9

ZEXEL - Test values
Injection pumps



C10

ZEXEL - Test values
Injection pumps



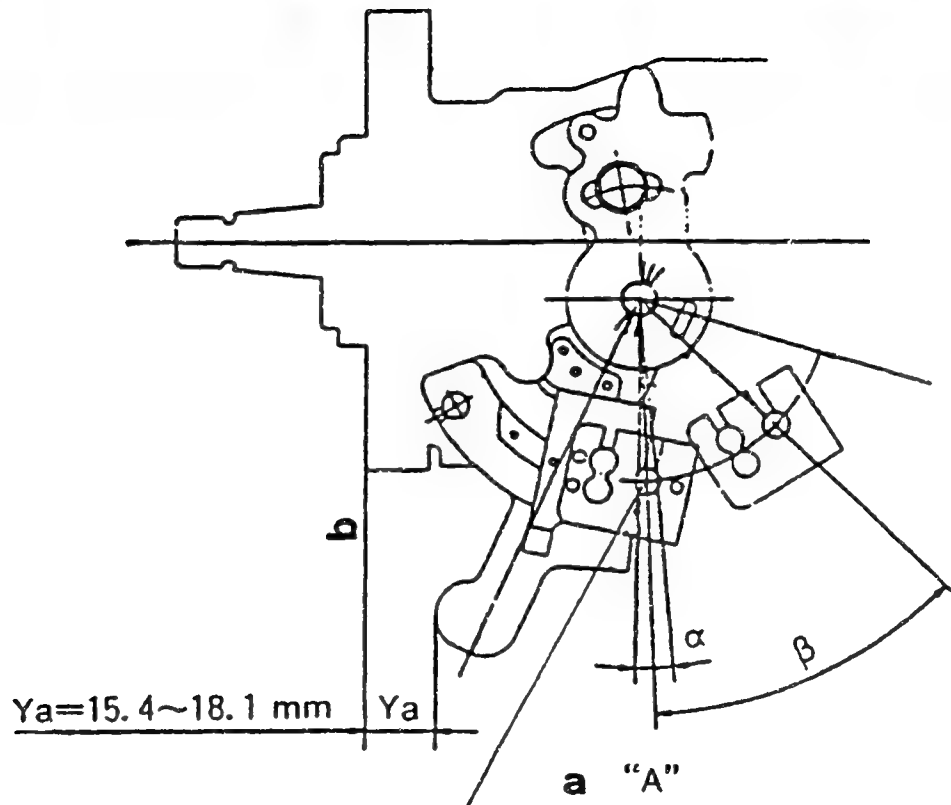

Figure 89

104748-2381 2/4

a = Hole
b = Flange

■ CONTROL LEVER ANGLE MEASUREMENT POSITION

1. Measure the control lever angles (α , β , γ) at hole „A“.

C11

ZEXEL - Test values

Injection pumps



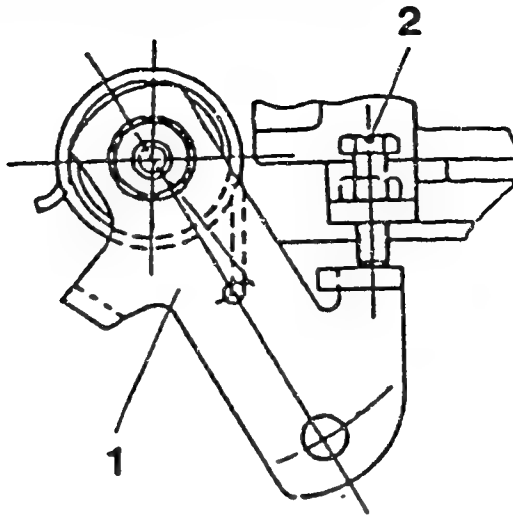

Figure 90

104748-2381 2/4
(continued)

- 1 = Stop lever
- 2 = Adjusting bolt

■ STARTING INJECTION QUANTITY ADJUSTMENT

Adjust the starting injection quantity
(item 1-5) using the adjusting bolt.



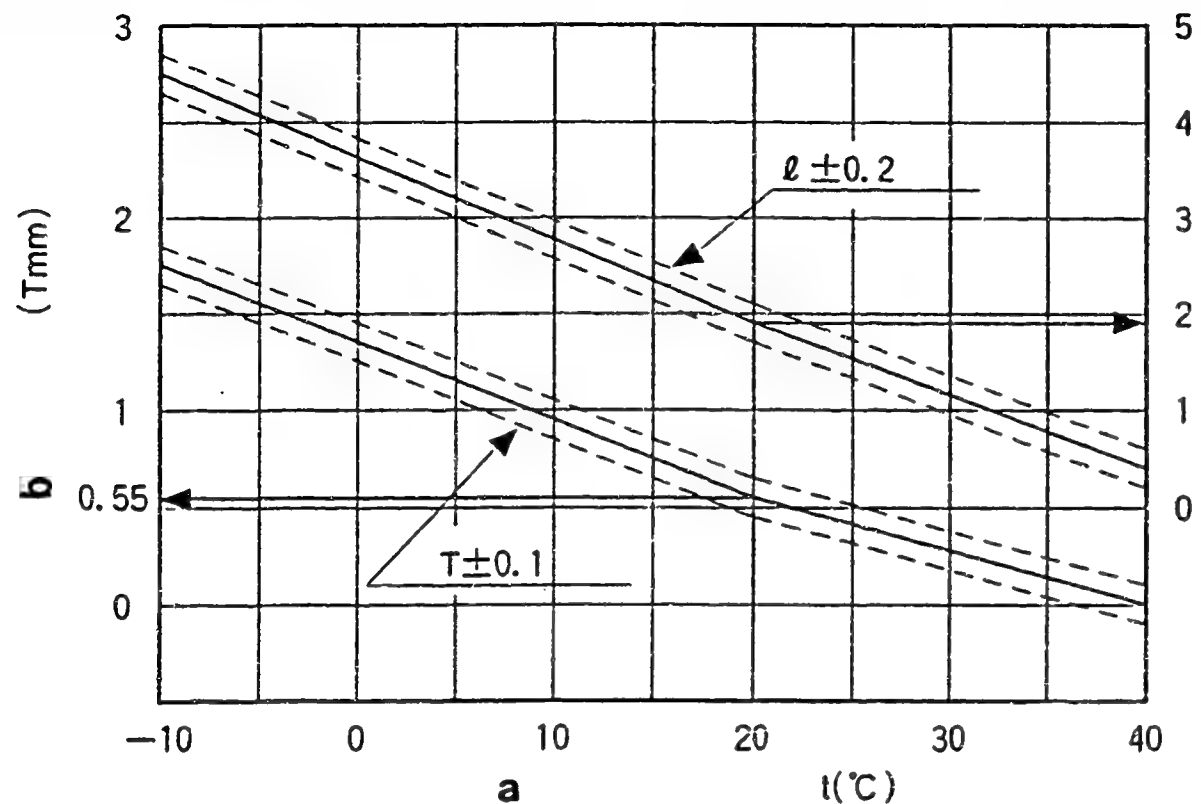

Figure 91

a = Atmospheric temperature
 b = Timer stroke
 c = Gap between control lever
 and idling stopper bolt

■ W-CSD ADJUSTMENT

1. Timer Stroke Adjustment (adjust to the thick line)

- 1) Calculate the timer stroke from Fig. 91 according to the atmospheric temperature at the time of adjustment.
- 2) Adjust using the timer stroke adjusting screw so that the timer stroke is as calculated in Step 1.

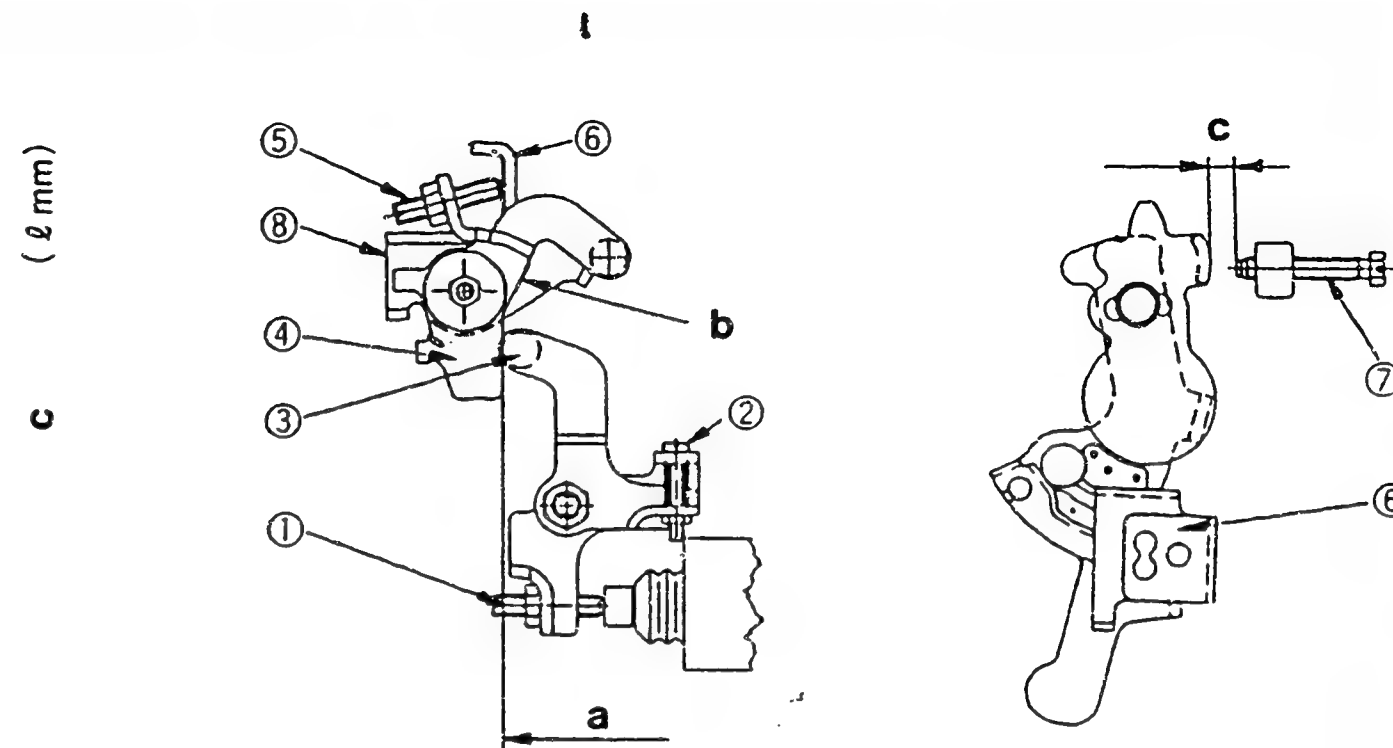

Figure 92

a = Vertical position
 b = Aligning mark
 c = Block gauge



(Continued)

2. Intermediate Lever Position Adjustment

- 1) Insert a block gauge (thickness gauge) of 1.9 ± 0.05 mm thickness between the control lever and the idling stopper bolt.
- 2) Align the intermediate lever with the aligning mark.
- 3) Adjust the intermediate lever set screw so that the control lever and the intermediate lever set screw are in contact, and then fix in position using the locknut.

3. CSD Lever Adjustment (adjust to the thick line)

- 1) Calculate the block gauge dimension $l \pm 0.05$ mm from Fig. 91 according to the atmospheric temperature at the time of adjustment.
- 2) Insert the block gauge (thickness gauge) between the control lever and the idling stopper bolt.
- 3) Using the idling bolt, adjust so that the CSD lever roller and the intermediate lever are in contact.

4. Final Adjustment

After completing the adjustment, screw the timer stroke adjusting screw two turns clockwise.
(Move from the temporary adjustment chart to the final adjustment chart).

C15

ZEXEL - Test values
Injection pumps

**C16**

ZEXEL - Test values
Injection pumps



Note:

1. The temperature of the wax must be below 30°C when adjusting.
2. When inserting a block gauge (thickness gauge) between the control lever (bracket) and the idling stopper bolt, use the idling adjusting bolt to separate the CSD lever and the intermediate lever so that no excessive force is exerted on them.

$$-10 \leq \theta \text{ (}^\circ\text{C)} \leq 20$$

$$TA = -0.0367 \theta + 1.284$$

$$-10 \leq \theta \text{ (}^\circ\text{C)} \leq 20$$

$$l = -0.0867 \theta + 3.63$$

$$20 \leq \theta \text{ (}^\circ\text{C)} \leq 40$$

$$TA = -0.0275 \theta + 1.1$$

$$20 \leq \theta \text{ (}^\circ\text{C)} \leq 40$$

$$l = -0.075 \theta + 3.4$$

C17

ZEXEL - Test values

Injection pumps



C18

ZEXEL - Test values

Injection pumps



Test oil:
ISO 4113 or
SAE J967d

ZEXEL - TEST VALUES
Distributor pumps
Engine model: CD17

1/4

BOSCH No.	9 460 610 534
ZEXEL No.	104748-2391
Date:	31.10.1992 [2]
Company:	NISSAN
No.	16700 16A73

Injection pump no.: 104648-2181

(NP-VE4/8F2500LNP164)

Pump rotation: Counter clockwise viewed from
drive side

Test-nozzle holder combination:
1 688 901 000

Test pressure line:
1 680 750 017

1. Setting values	P. Speed (rpm)	Setting values	Charge air pressure kPa (mmHg)	Difference in delivery (cm ³)
1-1 Timing device travel	1200	1.8 - 2.4 (mm)		
1-2 Supply pump pressure	1200	304-363(3.1-3.7) kPa (kgf/cm ²)		
1-3 Full load delivery	1200	29.5 - 30.5 (cm ³ /1000st)		2.5
Full load delivery		(cm ³ /1000st)		
1-4 Idle speed regulation	400	5.3 - 8.3 (cm ³ /1000st)		3.0
1-5 Start	100	45.3 - 55.3 (cm ³ /1000st)		
1-6 Full-load speed regulation	2700	11.9 - 17.9 (cm ³ /1000st)		
1-7 Load-timer adjustment				
1-8				

2. Test values

2-1 Timing device	N = rpm mm	1200 1.7 - 2.5	1800 4.0 - 5.2	2500 6.8 - 8.0
2-2 Supply pump	N = rpm kPa (kgf/cm ²)	1200 294 - 373 (3.0 - 3.8)	1800 431 - 510 (4.4 - 5.2)	2500 598 - 677 (6.1 - 6.9)
2-3 Overflow delivery	N = rpm cm ³ /10s	1200 36.0 - 80.0		

2-4 Fuel injection quantities

Control lever position	Pump Speed (rpm)	Fuel delivery (cm ³ /1000 strokes)	Charge air pressure kPa (mmHg)
End stop	1200	29.0 - 31.0	
	600	24.8 - 28.8	
	2500	26.7 - 30.7	
	2700	11.4 - 18.4	
	2900	below 6.0	
Switch off	400	0	
Idle stop	400	4.8 - 8.8	
	600	below 3.0	
Partial load	700	10.0 - 20.0	

2-5 Solenoid
Cut-in voltage max. 8 V
Test voltage: 12 - 14 V

3. Dimensions

K	3.2 - 3.4 mm
KF	5.7 - 5.9 mm
MS	1.7 - 1.9 mm
BCS	- mm
Pre-str.	- mm
Control lever angle	
α	1° - -1° deg
Ya	15.4 - 18.1 mm
β	39° - 49° deg
B	11.0 - 16.0 mm
γ	13.5° - 14.5° deg
C	8.6 - 9.2 mm

C19

ZEXEL - Test values
Injection pumps



C20

ZEXEL - Test values
Injection pumps



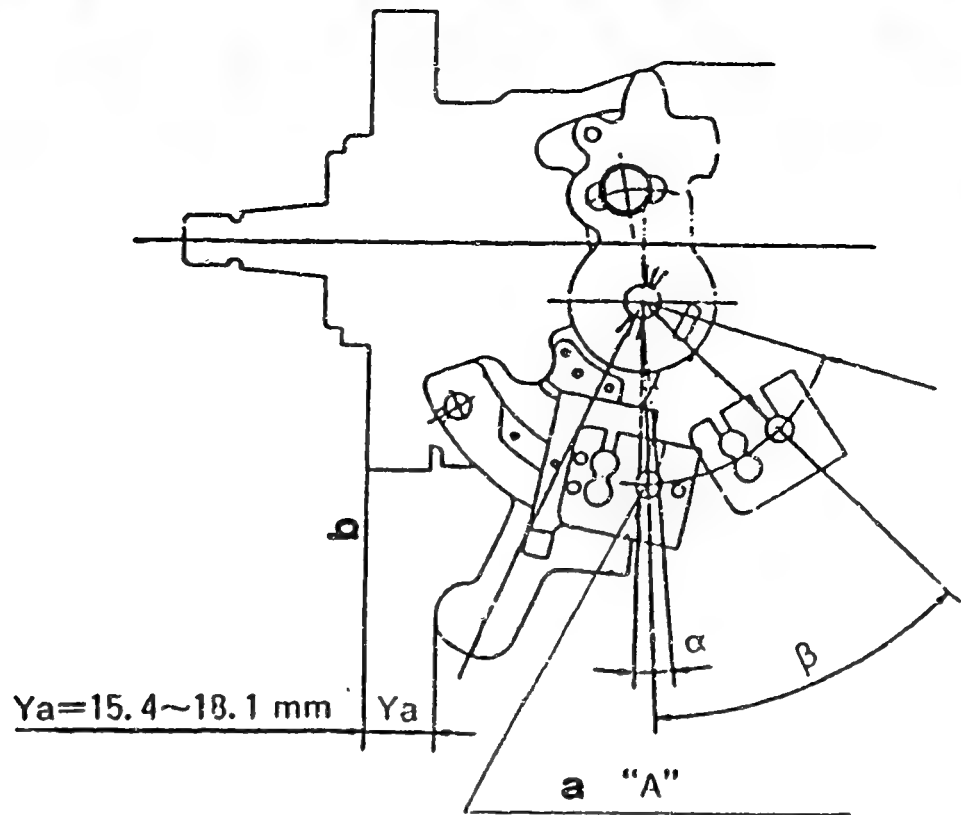

Figure 93

104748-2391 2/4

a = Hole
b = Flange

■ CONTROL LEVER ANGLE MEASUREMENT POSITION

1. Measure the control lever angles (α , β , γ) at hole "A".

C21

ZEXEL - Test values
Injection pumps



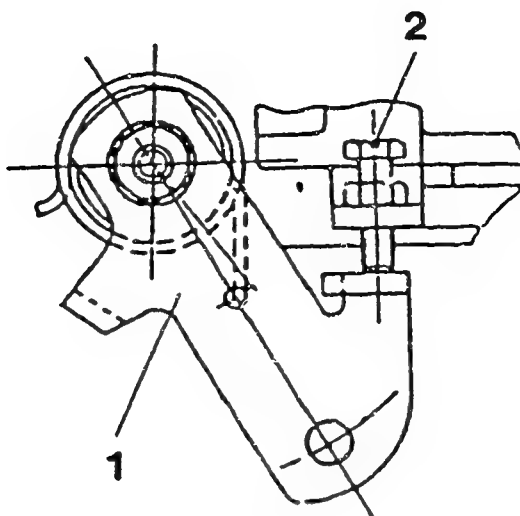

Figure 94

104748-2391 2/4
(continued)

- 1 = Stop lever
- 2 = Adjusting bolt

■ STARTING INJECTION QUANTITY ADJUSTMENT

Adjust the starting injection quantity
(item 1-5) using the adjusting bolt.



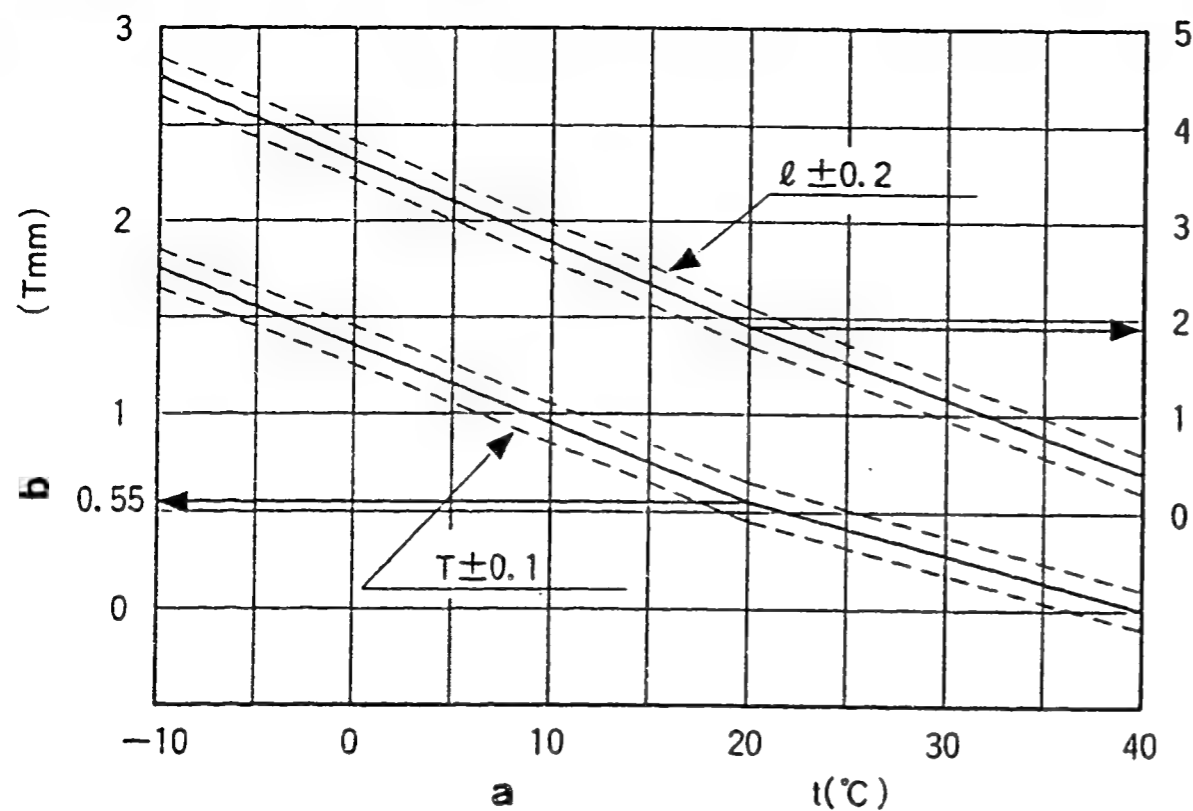

Figure 95

a = Atmospheric temperature
 b = Timer stroke
 c = Gap between control lever
 and idling stopper bolt

■ W-CSD ADJUSTMENT

1. Timer Stroke Adjustment (adjust to the thick line)

- 1) Calculate the timer stroke from Fig. 95 according to the atmospheric temperature at the time of adjustment.
- 2) Adjust using the timer stroke adjusting screw so that the timer stroke is as calculated in Step 1.

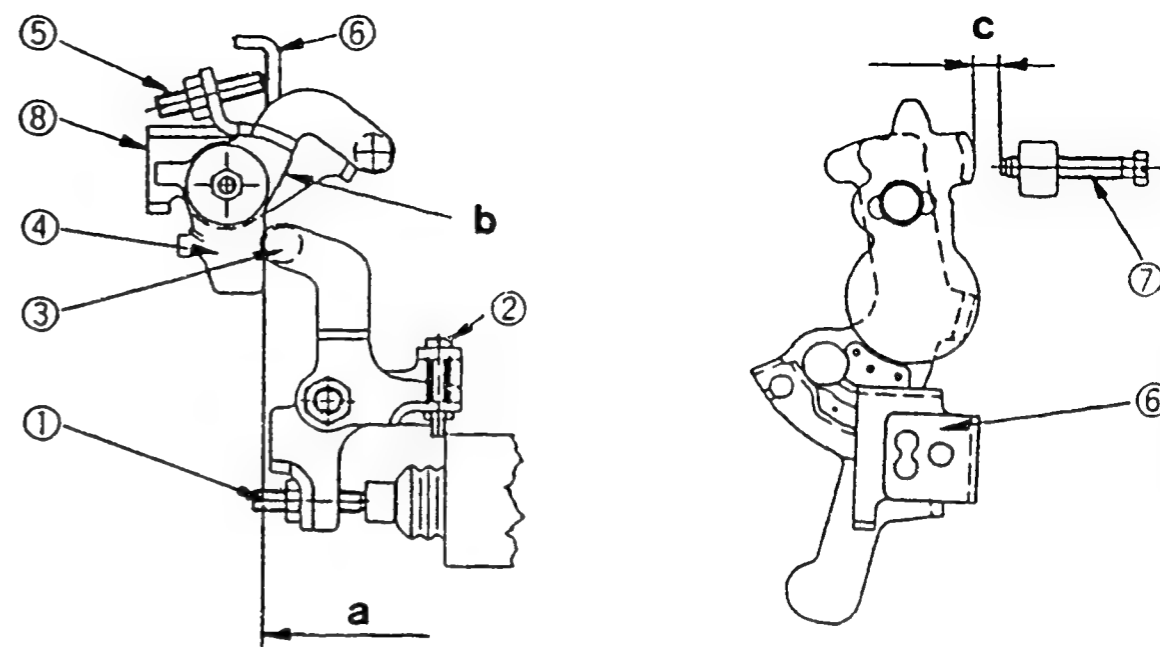

Figure 96

a = Vertical position
 b = Aligning mark
 c = Block gauge



(Continued)

2. Intermediate Lever Position Adjustment

- 1) Insert a block gauge (thickness gauge) of 1.9 ± 0.05 mm thickness between the control lever and the idling stopper bolt.
- 2) Align the intermediate lever with the aligning mark.
- 3) Adjust the intermediate lever set screw so that the control lever and the intermediate lever set screw are in contact, and then fix in position using the locknut.

3. CSD Lever Adjustment (adjust to the thick line)

- 1) Calculate the block gauge dimension $l \pm 0.05$ mm from Fig. 95 according to the atmospheric temperature at the time of adjustment.
- 2) Insert the block gauge (thickness gauge) between the control lever and the idling stopper bolt.
- 3) Using the idling bolt, adjust so that the CSD lever roller and the intermediate lever are in contact.

4. Final Adjustment

After completing the adjustment, screw the timer stroke adjusting screw two turns clockwise.
(Move from the temporary adjustment chart to the final adjustment chart).

C25

ZEXEL - Test values
Injection pumps

**C26**

ZEXEL - Test values
Injection pumps



Note:

1. The temperature of the wax must be below 30°C when adjusting.
2. When inserting a block gauge (thickness gauge) between the control lever (bracket) and the idling stopper bolt, use the idling adjusting bolt to separate the CSD lever and the intermediate lever so that no excessive force is exerted on them.

$$-10 \leq \theta \text{ (}^\circ\text{C)} \leq 20$$

$$TA = -0.0367 \theta + 1.284$$

$$-10 \leq \theta \text{ (}^\circ\text{C)} \leq 20$$

$$l = -0.0867 \theta + 3.63$$

$$20 \leq \theta \text{ (}^\circ\text{C)} \leq 40$$

$$TA = -0.0275 \theta + 1.1$$

$$20 \leq \theta \text{ (}^\circ\text{C)} \leq 40$$

$$l = -0.075 \theta + 3.4$$

C27

ZEXEL - Test values
Injection pumps



C28

ZEXEL - Test values
Injection pumps



Test oil
ISO 4113 or
SAE J967d

ZEXEL - TEST VALUES
Distributor pumps
Engine model: C223

1/2

BOSCH No. 9 460 610 540
ZEXEL No. 104749-1213
Date: 31.10.1992 [1]
Company: ISUZU
No. 8942528142

Injection pump no.: 104649-1202 (NP-VE4/9F2175LNP125)

Pump rotation: Counter clockwise-viewed from drive side
Test-nozzle holder combination: 1 688 901 000
Test pressure line: 1 680 750 017

1. Setting values		P. Speed (rpm)	Setting values	Charge-air pressure kPa (mmHg)	Difference in delivery (cm ³)
1-1	Timing device travel	1500	3.8 - 4.2 (mm)		
1-2	Supply pump pressure	1500	510-549(5.2-5.6) kPa (kgf/cm ²)		
1-3	Full load delivery	1500	37.9 - 38.9 (cm ³ /1000st)		3.0
	Full load delivery		(cm ³ /1000st)		
1-4	Idle speed regulation	350	5.5 - 9.5 (cm ³ /1000st)		2.0
1-5	Start	100	above 63.0 (cm ³ /1000st)		
1-6	Full-load speed regulation	2440	10.4 - 16.4 (cm ³ /1000st)		
1-7	ACS adjustment	1500	Decrease 4.8-6.2 (cm ³ /1000st)	-21.9±0.7 (-164±5)	

2. Test values

2-1 Timing device	N = rpm mm	1000 1.4-2.6	1500 3.7-4.3	2175 6.1-7.0	
2-2 Supply pump	N = rpm kPa (kgf/cm ²)	1000 373-431 (3.8-4.4)	1500 510-549 (5.2-5.6)	2175 647-706 (6.6-7.2)	
2-3 Overflow delivery	N = rpm cm ³ /10s	1000 52.0-95.0			
2-4 Fuel injection quantities					
Speed control lever pos.	P. Speed (rpm)	Fuel delivery (cm ³ /1000st)	Charge-air press. kPa (mmHg)	Difference deliv. (cm ³)	
End stop	1500	37.4 - 39.4			
	600	28.4 - 32.4			
	1500	Decrease 4.3-6.7	-21.9±0.7 (-164±5)		
	2175	33.3 - 37.5			
	2440	10.4 - 16.4			
	2550	below 6.0			
Switch off	350	0			
Idle-stop	350	5.5 - 9.5			
	450	below 3.0			
2-5 Solenoid	Cut-in voltage max.:8V Test voltage: 12 - 14V				

3. Dimensions

K	3.2 - 3.4 mm
KF	5.7 - 5.9 mm
MS	1.7 - 1.9 mm
BCS	- mm
Pre-st.	- mm
Control lever angle	
α	21° - 29° deg
A	- mm
β	36.5° - 46.5° deg
B	- mm
γ	- deg
C	- mm

D1

ZEXEL - Test values

Injection pumps



D2

ZEXEL - Test values

Injection pumps



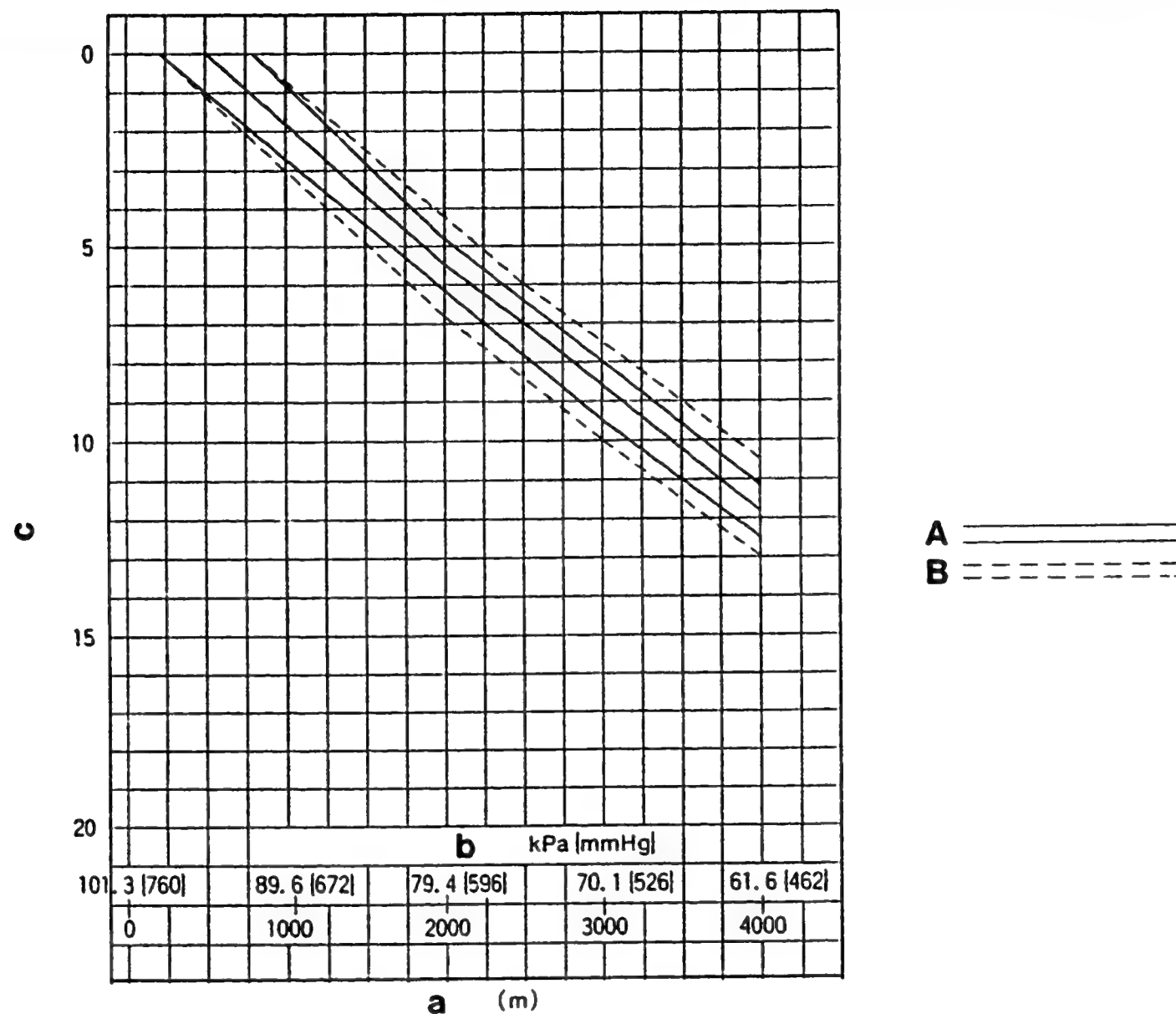

Figure 97

104749-1213 2/2

a = Altitude
 b = Atmospheric pressure
 c = Injection quantity decrease (cm³/1000st)

A = Adjustment value
 B = Inspection value

■ FULL-LOAD FUEL INJECTION QUANTITY AND ACS ADJUSTING PROCEDURE AT HIGH ALTITUDES

1. FULL-LOAD FUEL INJECTION QUANTITY ADJUSTMENT

- 1) Remove the ACS cover, the bellows and the adjusting shims.
- 2) Perform all adjustments as described in the adjusting specifications, except for ACS adjustment.

2. ACS ADJUSTMENT

- 1) Attach the ACS cover, the bellows and the adjusting shims.
- 2) At a pump speed of 1500 rpm and referring to the graph above, use the shims to adjust the fuel injection quantity decrease according to the altitude.

D3

ZEXEL - Test values
 Injection pumps



D4

ZEXEL - Test values
 Injection pumps



ZEXEL - TEST VALUES
Injection pumps

BOSCH No.	:	9 400 610 187	1/4
ZEXEL No.	:	106672-4572	
Date	:	31.10.1992	[3]
Company	:	KOMATSU	
Engine	:	SA6D155 / 6128-71-1035	

IP-Type number	:	106067-8151 / PES6PD
Governor type number	:	105448-9362 / EP/RSUV

TEST PREREQUISITES

Test oil	:	ISO-4113
Test oil inlet temperature °C	:	40.00...45.00
Inlet pressure bar	:	1.6
Test nozzle holder combination	:	0 681 343 002
Opening pressure bar	:	175
Test pressure line		
Inner x Outer Dia - Length mm	:	3.00 x 8.00 x 600

PORT CLOSING

Prestroke	mm	:	2.5 ± 0.05
Rod position	mm	:	-
Port closing mark Cyl. No.	:	:	-
Cam sequence	:	:	1-5-3-6-2-4
Port closing mark Cyl. No.	:	:	-
Port closing difference °NW	:	:	0-60-120-180-240-300
Tolerance	+ - °C	:	0.50 (0.75)

D5

ZEXEL - Test values
Injection pumps



Injection Quantity :

Adjusting Point	Rack Pos. (mm)	P. Speed (rpm)	Injection Q'ty (cm ³ /1000 str.)	Difference (%)	Fixed	Remarks
A	14.3	1000	250.0 ± 5.0	-	Rack	Basic Each cylinder
H	8.6	300	28.0 ± 3.0	± 10.0	Rack	
A	14.3	1000	250.0 ± 5.0	-	Lever	Basic Each cylinder
B	16.5	1000	335.0 ± 2.0	-	Lever	
C	16.5	700	315.0 ± 5.0		Lever	
D	14.6	400	254.0 ± 5.0		Lever	

Timing Advance Specification :

Pump Speed (rpm)					
Advance Angle (deg)					

D6

ZEXEL - Test values

Injection pumps



D7

ZEXEL - Test values

Injection pumps



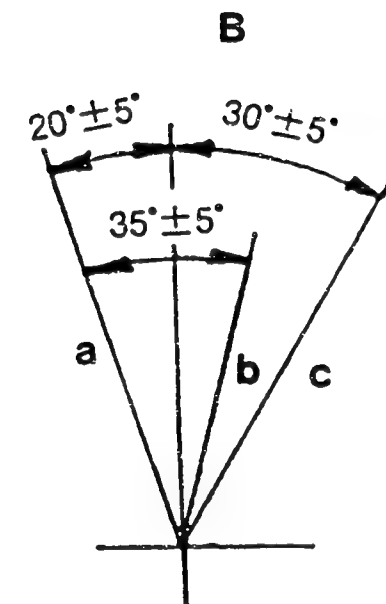
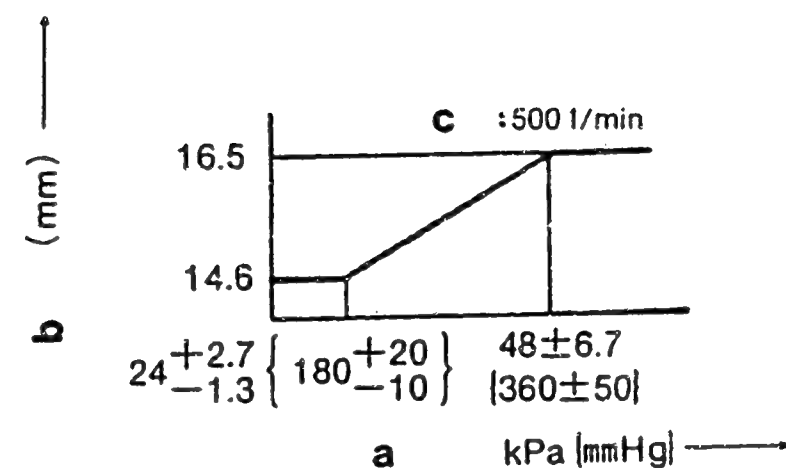
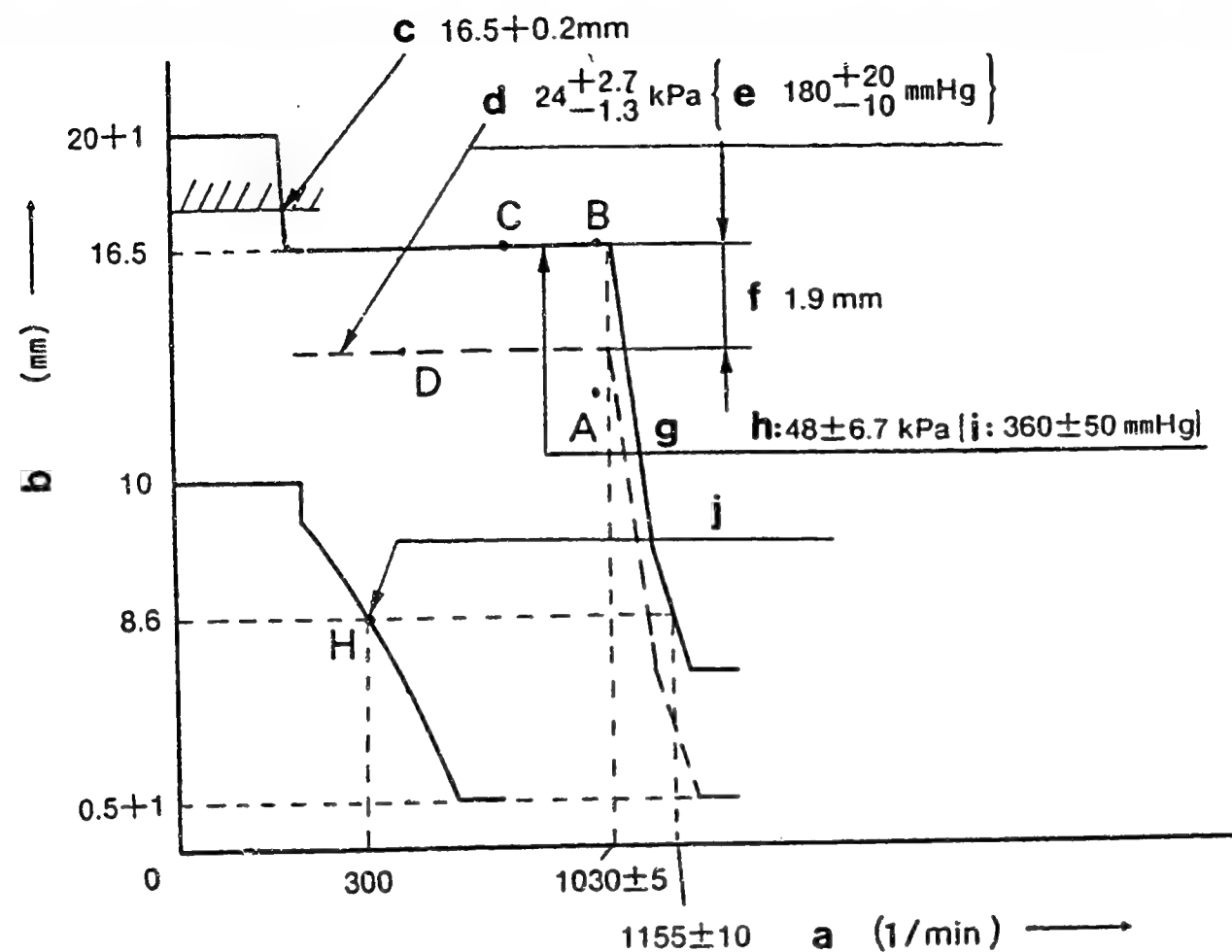

Figure 98 GOVERNOR ADJUSTMENT

Recommended speed droop adjustment screw position: 18
Perform torque control spring adjustment when necessary

106672-4572 2/4

- a = Pump speed
- b = Control rack position
- c = Control rack limit setting:
- d = Boost pressure: e = below:
- f = Boost compensator stroke:
- g = Boost pressure: h/i = above:
- j = Idle setting
(Using boost pressure 0)

- A** = BOOST COMPENSATOR ADJUSTMENT
- a = Boost pressure
- b = Control rack position
- c = Pump speed:
- B** = Speed Control Lever Angle
- a = Full-speed
- b = Idling
- c = Stop

D8

ZEXEL - Test values
Injection pumps



D9

ZEXEL - Test values
Injection pumps



■ Note

- Before adjustment, remove the idling sub spring.
- Move the control lever fully in the stop direction, and set the minimum-speed stopper bolt so that the control rack position is 0.5 - 1.0 mm.

■ ADJUSTMENT

		Pump Speed (rpm)	Rack Position (mm)	Boost pressure kPa (mmHg)	Remarks
Full-load Adjustment (Temporary)		1230 700	16.5 16.5	0 0	<ul style="list-style-type: none"> • Adjust using screw (2) • Adjust using screw (1)
Torque Control Spring Adjust- ment	1.st stroke	-	-	-	<ul style="list-style-type: none"> • Adjust using spring capsule (4) • Confirm • Confirm the torque control stroke is: (mm)
	2.st stroke	-	-	-	<ul style="list-style-type: none"> • Adjust using spring capsule (4) • Confirm • Confirm the torque control stroke is: (mm)
Maximum Speed Adjustment		1030 1155 ± 10	16.5 8.6	-	<ul style="list-style-type: none"> • Fix the control lever • Confirm speed droop - adjust using screw (3) • Confirm
Boost Compensator System		500 500	14.6 16.5	24+2.7 -1.3 (180+20) -10 48 ± 6.7 (360 ± 50)	<ul style="list-style-type: none"> • Fix the control lever • Adjust using screw (6) • Confirm the boost compensator stroke is: 1.9 mm
Idling Adjustment		0 300 above 500	10.0 8.6 0.5 ± 1	0 0 0	<ul style="list-style-type: none"> • Fix the control lever • Adjust using spring capsule (5) • Confirm
1. Idling Sub Spring					
2. Control Lever		-	-	-	<ul style="list-style-type: none"> • Adjust using the control lever
Full-load Adjustment		1030	16.5	above 48 ± 6.7 (360 ± 50)	<ul style="list-style-type: none"> • Confirm
Control Lever Angle Measurement		<ul style="list-style-type: none"> • Measure the control lever angle at the "idling" and "full" positions. • When the control lever is depressed toward the "full" position, replace the shifter's shim with a thicker one. • When the control lever is depressed toward the "idling" position, replace the shifter's shim with a thinner one. 			
Control Rack Limiter Adjustment		-	16.5 + 0.2	-	<ul style="list-style-type: none"> • Adjust using screw

D10

ZEXEL - Test values
Injection pumps



D11

ZEXEL - Test values
Injection pumps



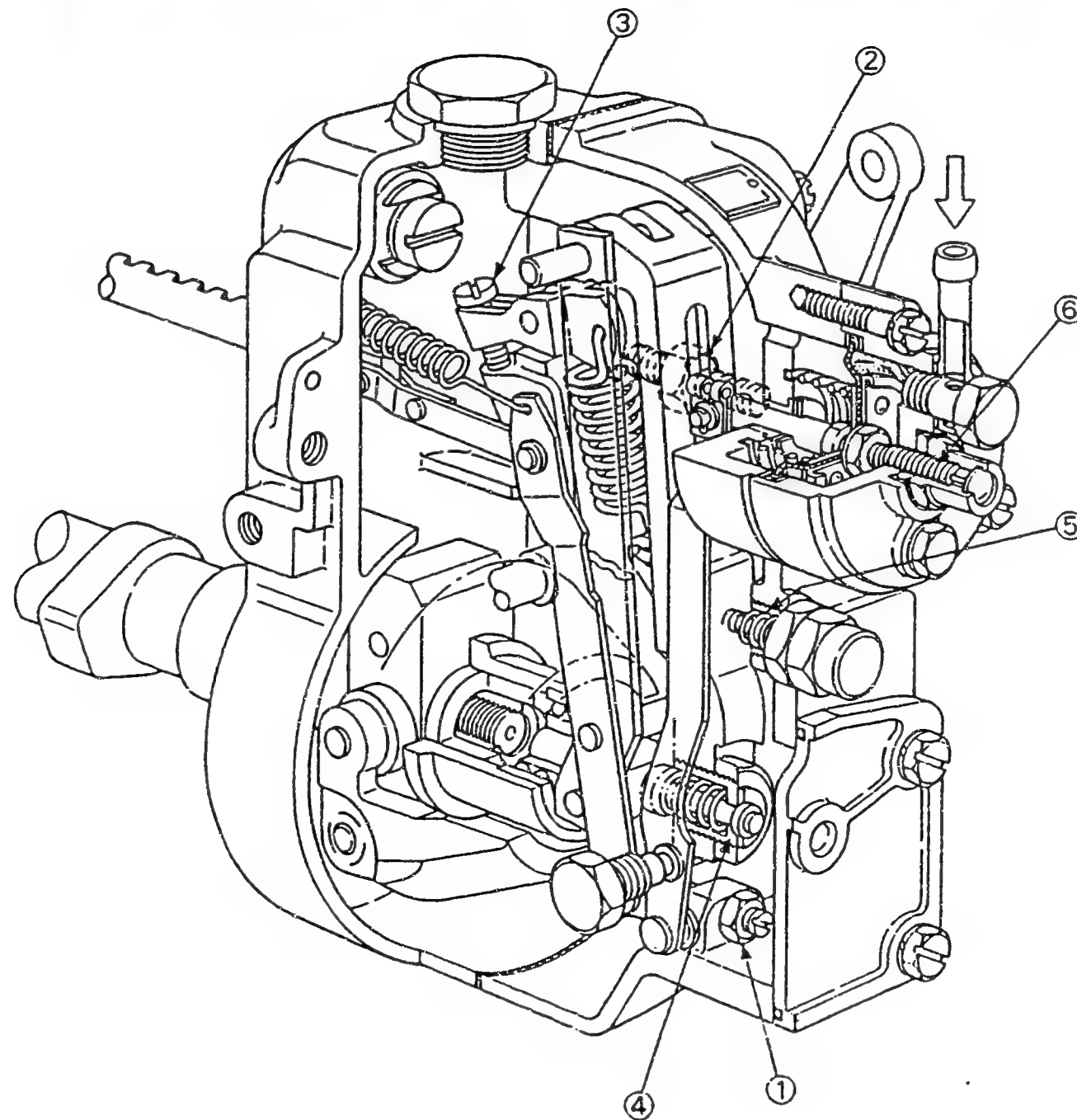

Figure 99

- 1 = Screw
- 2 = Screw
- 3 = Screw
- 4 = Spring capsule
- 5 = Spring capsule
- 6 = Screw

106672-4572 4/4

D12

ZEXEL - Test values
Injection pumps



D13

ZEXEL - Test values
Injection pumps



ZEXEL - TEST VALUES
Injection pumps

BOSCH No.	:	9 400 610 225	1/4
ZEXEL No.	:	106672-4591	
Date	:	31.10.1992	[4]
Company	:	KOMATSU	
Engine	:	SA6D155 / 6128-71-1084	

IP-Type number : 106067-8151 / PES6PD
Governor type number : 105448-9362 / EP/RSUV

TEST PREREQUISITES

Test oil : ISO-4113
Test oil inlet temperature °C : 40.00...45.00
Inlet pressure bar : 1.6
Test nozzle holder combination : 0 681 343 002
Opening pressure bar : 175
Test pressure line
Inner x Outer Dia - Length mm : 3.00 x 8.00 x 600

PORT CLOSING

Prestroke mm : 2.5 ± 0.05
Rod position mm : -
Port closing mark Cyl. No. : -
Cam sequence : 1-5-3-6-2-4

Port closing mark Cyl. No. : -
Port closing difference °NW : 0-60-120-180-240-300

Tolerance +- °C: 0.50 (0.75)



Injection Quantity :

Adjusting Point	Rack Pos. (mm)	P. Speed (rpm)	Injection Q'ty (cm ³ /1000 str.)	Difference (%)	Fixed	Remarks
A	14.3	1000	250.0 ± 5.0	-	Rack	Basic Each cylinder
H	8.6	300	28.0 ± 3.0	± 10.0	Rack	
A	14.3	1000	250.0 ± 5.0	-	Lever	Basic Each cylinder
B	16.5	1000	335.0 ± 2.0	-	Lever	Boost pressure kPa (mmHg) above 48±6.7 (above 360±50)
C	16.5	700	315.0 ± 5.0	-	Lever	Boost pressure kPa (mmHg) above 48±6.7 (above 360±50)
D	14.6	400	254.0 ± 5.0	-	Lever	

Timing Advance Specification :

Pump Speed (rpm)					
Advance Angle (deg)					

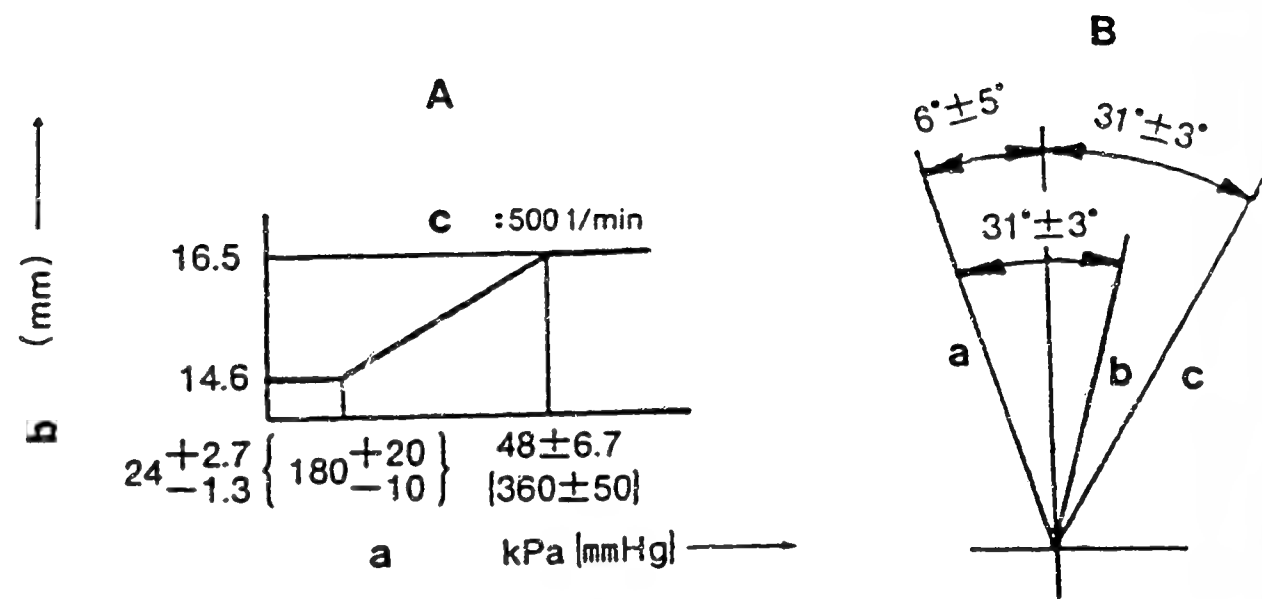
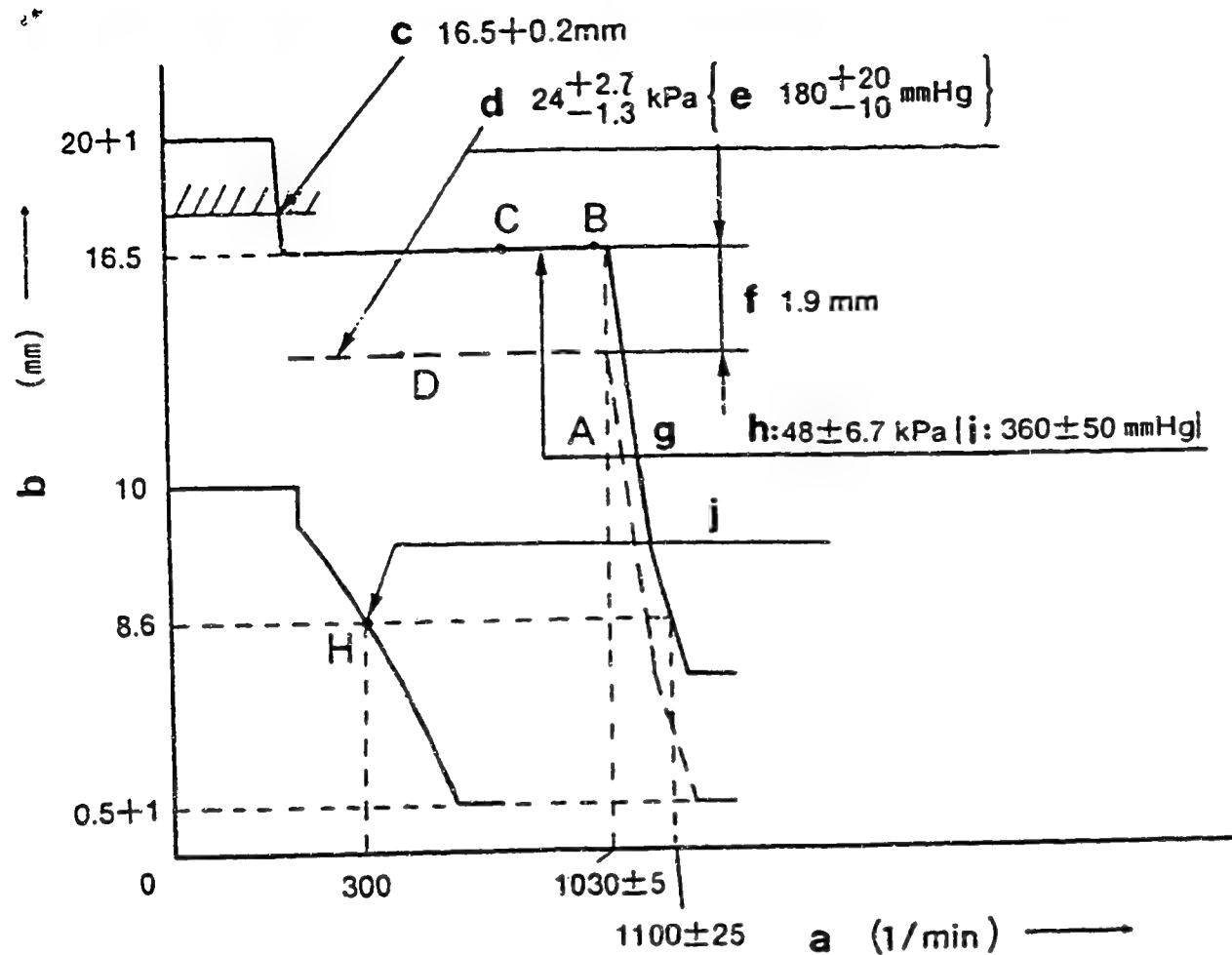

Figure 100 GOVERNOR ADJUSTMENT

Recommended speed droop adjustment screw position: 10
Perform torque control spring adjustment when necessary

106672-4591 2/4

- a = Pump speed
- b = Control rack position
- c = Control rack limit setting:
- d = Boost pressure: e = below:
- f = Boost compensator stroke:
- g = Boost pressure: h/i = above:
- j = Idle setting
(Using boost pressure 0)

- A = BOOST COMPENSATOR ADJUSTMENT
- a = Boost pressure
- b = Control rack position
- c = Pump speed:
- B = Speed Control Lever Angle
- a = Full-speed
- b = Idling
- c = Stop

D17

ZEXEL - Test values
Injection pumps



D18

ZEXEL - Test values
Injection pumps



■ Note

- Before adjustment, remove the idling sub spring.
- Move the control lever fully in the stop direction, and set the minimum-speed stopper bolt so that the control rack position is 0.5 - 1.0 mm.

■ ADJUSTMENT

		Pump Speed (rpm)	Rack Position (mm)	Boost pressure kPa (mmHg)	Remarks
Full-load Adjustment (Temporary)		1230 700	16.5 16.5	0 0	<ul style="list-style-type: none"> • Adjust using screw (2) • Adjust using screw (1)
Torque Control Spring Adjust- ment	1.st stroke	-	-	-	<ul style="list-style-type: none"> • Adjust using spring capsule (4) • Confirm • Confirm the torque control stroke is: (mm)
	2.st stroke	-	-	-	<ul style="list-style-type: none"> • Adjust using spring capsule (4) • Confirm • Confirm the torque control stroke is: (mm)
Maximum Speed Adjustment		1030 ± 5 1100 ± 25	16.5 8.6	-	<ul style="list-style-type: none"> • Fix the control lever • Confirm speed droop - adjust using screw (3) • Confirm
Boost Compensator System		500 500	14.6 16.5	24+2.7 -1.3 (180+20) -10 48 ± 6.7 (360 ± 50)	<ul style="list-style-type: none"> • Fix the control lever • Adjust using screw (6) • Confirm the boost compensator stroke is: 1.9 mm
Idling Adjustment	H	0	10.0	0	• Fix the control lever
1. Idling Sub Spring		300 above 500	8.6 0.5 ± 1	0 0	<ul style="list-style-type: none"> • Adjust using spring capsule (5) • Confirm
2. Control Lever		-	-	-	• Adjust using the control lever
Full-load Adjustment		1100	16.5	above 48 ± 6.7 (360 ± 50)	• Confirm
Control Lever Angle Measurement		<ul style="list-style-type: none"> • Measure the control lever angle at the "idling" and "full" positions. • When the control lever is depressed toward the "full" position, replace the shifter's shim with a thicker one. • When the control lever is depressed toward the "idling" position, replace the shifter's shim with a thinner one. 			
Control Rack Limiter Adjustment		-	16.5	-	• Adjust using screw

D19

ZEXEL - Test values
Injection pumps



D20

ZEXEL - Test values
Injection pumps



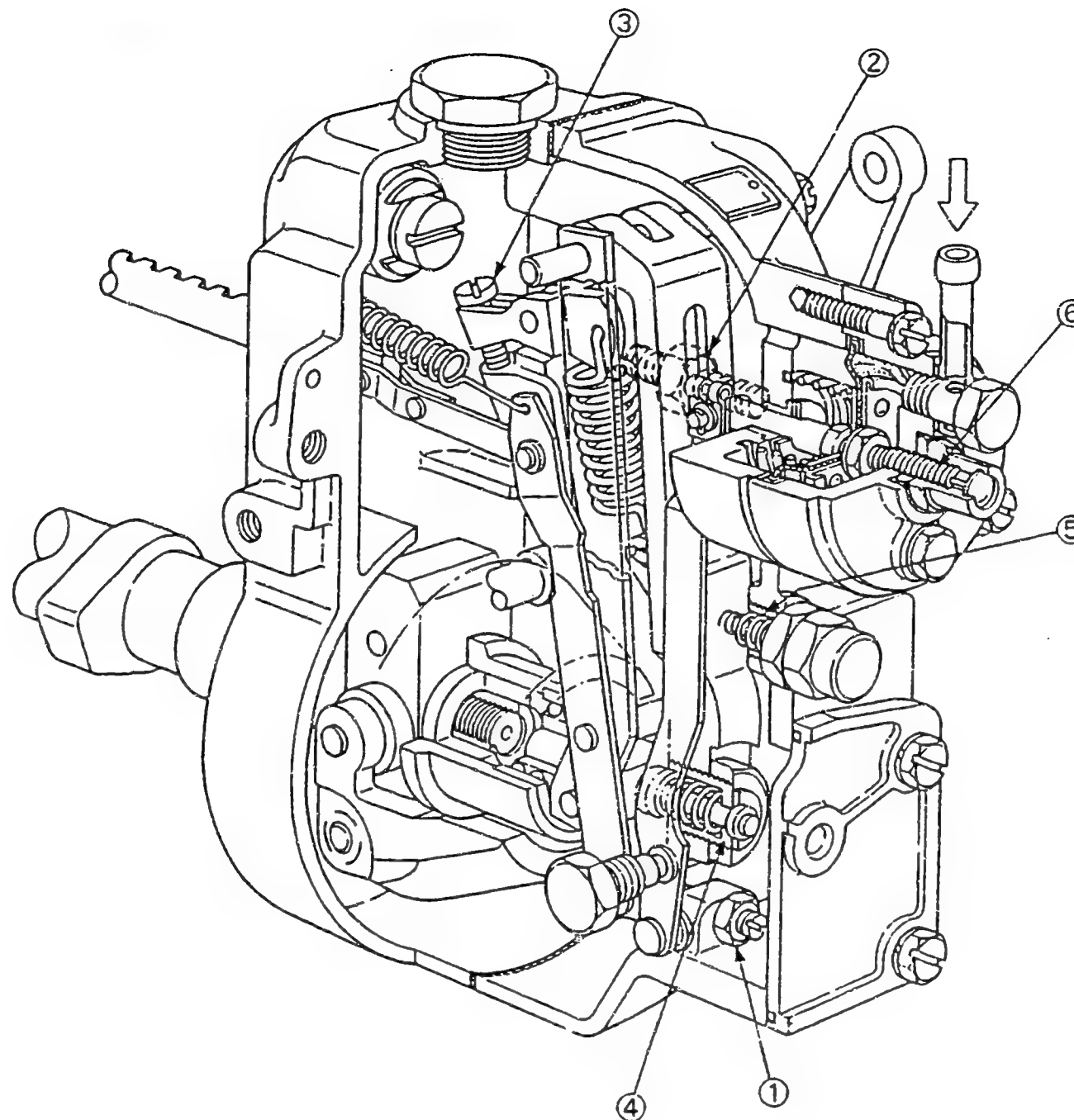

Figure 101

- 1 = Screw
- 2 = Screw
- 3 = Screw
- 4 = Spring capsule
- 5 = Spring capsule
- 6 = Screw

106672-4591 4/4

D21

ZEXEL - Test values
Injection pumps



D22

ZEXEL - Test values
Injection pumps



ZEXEL - TEST VALUES
Injection pumps

BOSCH No.	:	9 400 610 226	1/4
ZEXEL No.	:	106672-9124	
Date	:	31.10.1992	[2]
Company	:	KOMATSU	
Engine	:	SA6D125 / 6152-71-1191	

IP-Type number : 106060-5712 / PE 6P
Governor type number : 105407-3051 / EP/RSV

TEST PREREQUISITES

Test oil : ISO-4113
Test oil inlet temperature °C : 40.00...45.00
Inlet pressure bar : 1.6
Test nozzle holder combination : 0 681 343 002
Opening pressure bar : 175
Test pressure line
Inner x Outer Dia - Length mm : 3.00 x 8.00 x 600

PORT CLOSING

Prestroke mm : 3.8 ± 0.05
Rod position mm : -
Port closing mark Cyl. No. : -
Cam sequence : 1-5-3-6-2-4

Port closing mark Cyl. No. : -
Port closing difference °NW : 0-60-120-180-240-300

Tolerance +- °C: 0.50 (0.75)

E1

ZEXEL - Test values
Injection pumps



Continued (Test values)

Injection Quantity :

Adjusting Point	Rack Pos. (mm)	P. Speed (rpm)	Injection Q'ty (cm ³ /1000 str.)	Difference (%)	Fixed	Remarks
A	12.8	700	305.4 ± 2.0	± 3.0	Lever	Basic
H	approx. 5.7	375	14.6 ± 1.5	± 15.0	Rack	
A	12.8	700	305.4 ± 2.0	-	Lever	Basic
C	11.8	900	(264.7)	-	Lever	

Timing Advance Specification :

Pump Speed (rpm)						
Advance Angle (deg)						

E2

ZEXEL - Test values
Injection pumps



E3

ZEXEL - Test values
Injection pumps



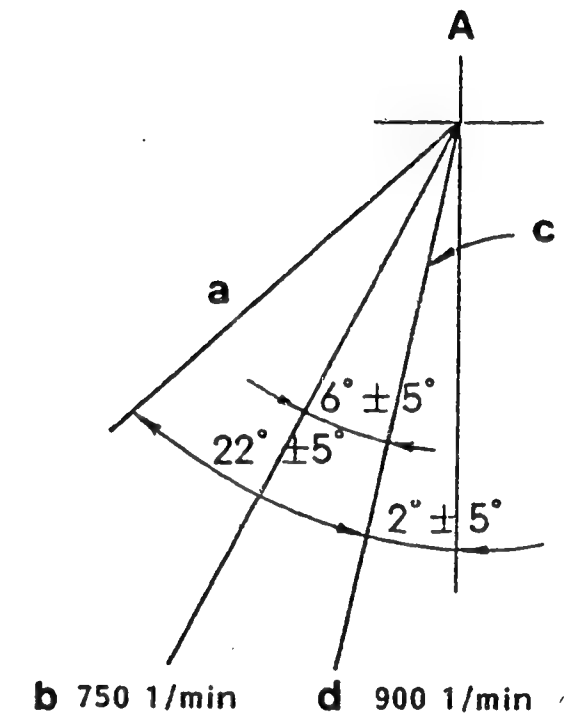
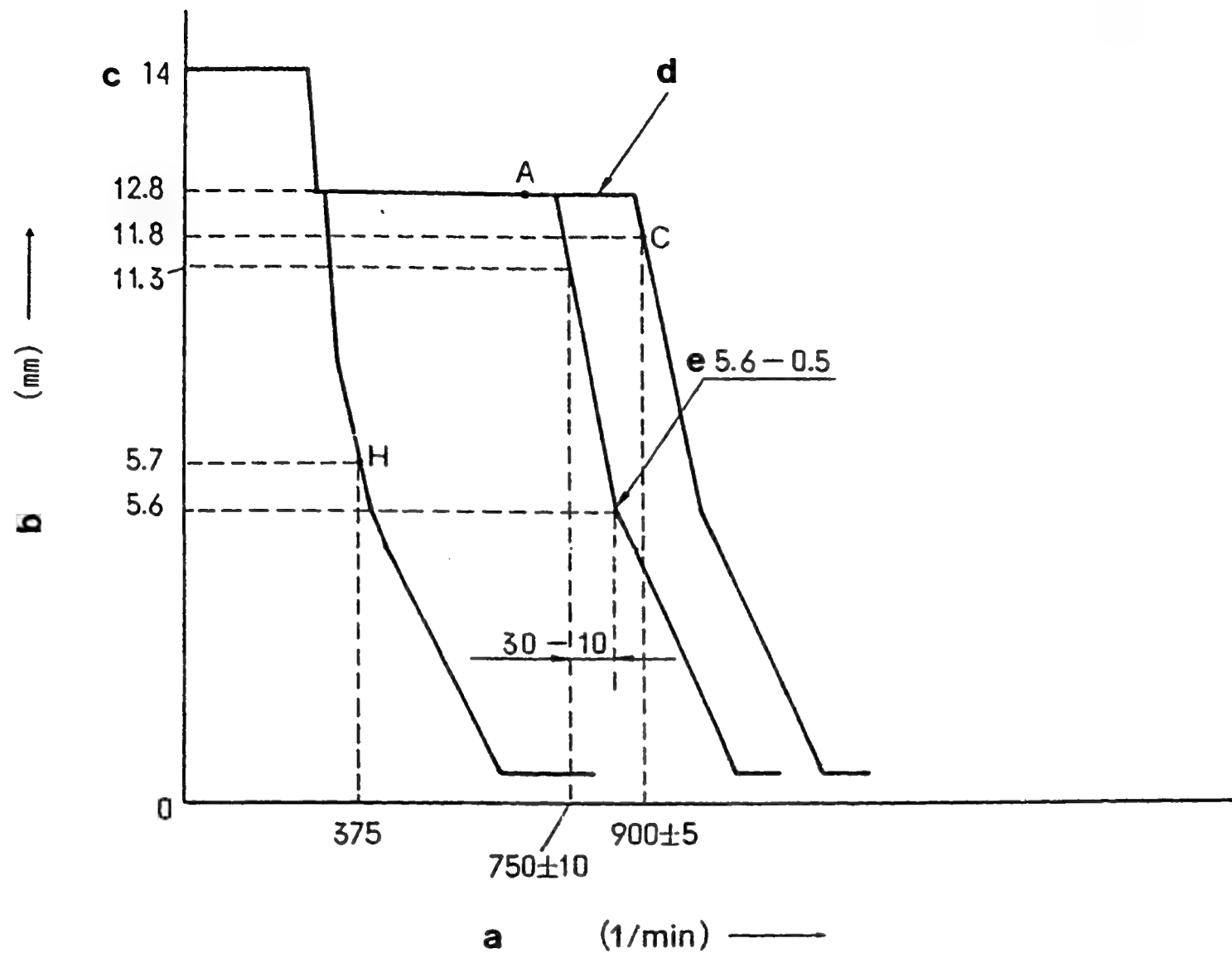

Figure 102

GOVERNOR ADJUSTMENT

106672-9124 2/4

Recommended speed droop adjustment screw position: 12

- a = Pump speed
- b = Control rack position
- c = Above
- d = Perform torque control spring adjustment when necessary
- e = Idle-sub spring setting:

A = Speed Control Lever Angle

- a = Idling
- b = Setting:
- c = Full-speed
- d = Setting:
(on our shipment)

E4	ZEXEL - Test values Injection pumps	← →
-----------	--	-----

E5	ZEXEL - Test values Injection pumps	← →
-----------	--	-----

■ Note

- Before adjustment, remove the idling sub spring.
- Move the control lever fully in the stop direction, and set the minimum-speed stopper bolt so that the control rack position is 0.5 - 1.0 mm.

■ ADJUSTMENT

	Pump speed (rpm)	Rack position (mm)	Remarks
Full-load Adjustment (Temporary)	1100 600	12.8 12.8	<ul style="list-style-type: none"> • Adjust using screw (2) • Adjust using screw (1)
Torque Control spring Adjustment	-	-	<ul style="list-style-type: none"> • Adjust using spring capsule (4) • Confirm • Confirm the torque control stroke is: (mm)
Idling Adjustment	750+30 +20 375	5.6 -0.5 5.7	<ul style="list-style-type: none"> • Fix the control lever • Adjust using spring capsule (5) • Adjust using control lever
Maximum-speed Adjustment	750 ± 10 750+30 +20 900 ± 5	11.3 5.6 11.8	<ul style="list-style-type: none"> • Fix the control lever • Confirm speed droop - adjust using screw (3) • Confirm • Fix the control lever • Adjust using screw (3)
Full-load Adjustment	850	12.8	<ul style="list-style-type: none"> • Confirm
Control Lever Angle Measurement	<ul style="list-style-type: none"> • Measure the control lever angle at the "idling" and "full" positions. • When the control lever is depressed toward the "full" position, replace the shifter's shim with a thicker one. • When the control lever is depressed toward the "idling" position, replace the shifter's shim with a thinner one. 		
Rack Limiter Adjustment	-	-	<ul style="list-style-type: none"> • Adjust using screw

E6

ZEXEL - Test values
Injection pumps



E7

ZEXEL - Test values
Injection pumps



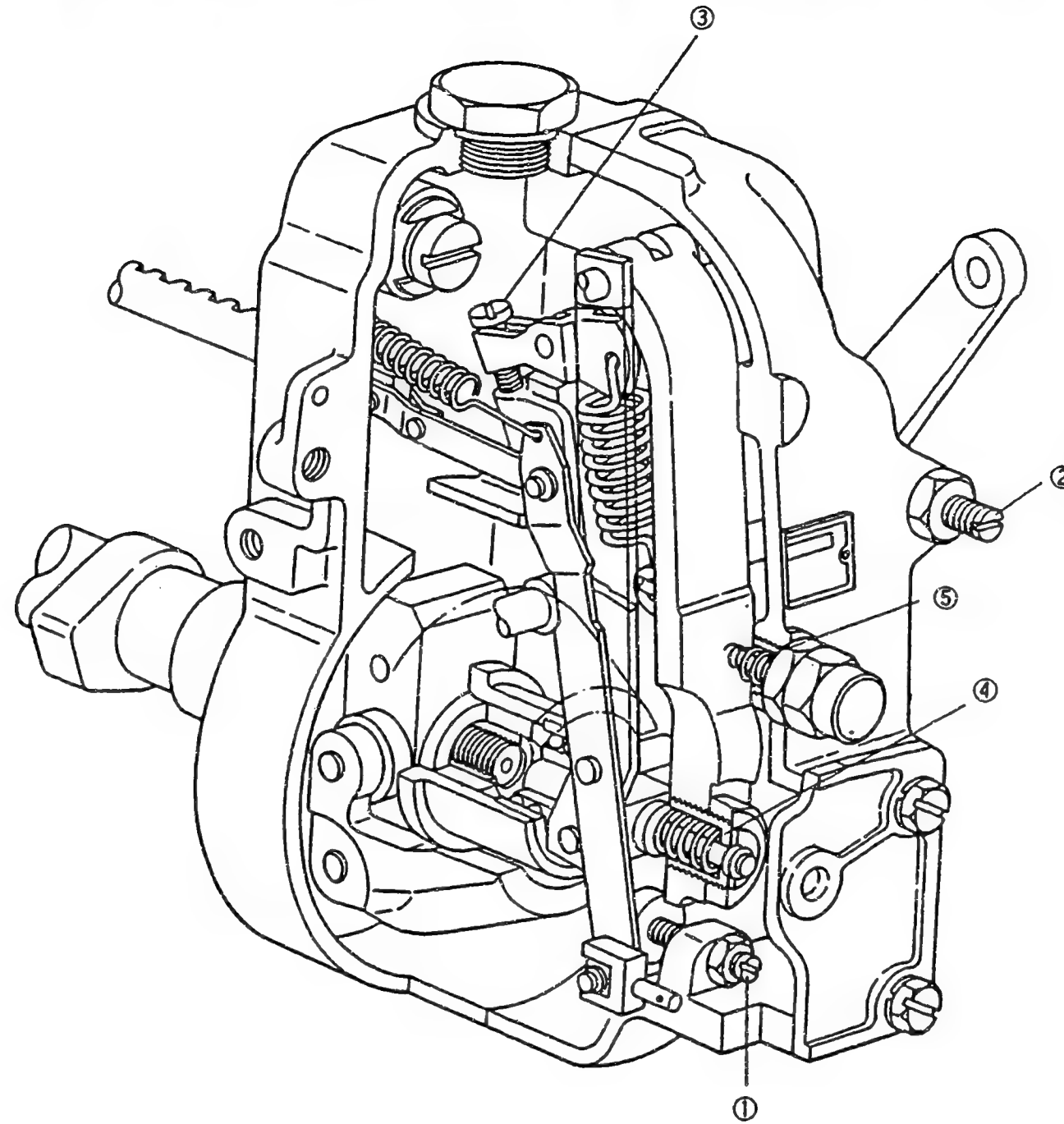

Figure 103

- 1 = Screw
- 2 = Screw
- 3 = Screw
- 4 = Spring capsule
- 5 = Spring capsule

106672-9124 4/4

E8

ZEXEL - Test values
Injection pumps



E9

ZEXEL - Test values
Injection pumps



ZEXEL - TEST VALUES
Injection pumps

BOSCH No.	:	9 400 610 227	1/4
ZEXEL No.	:	106672-9183	
Date	:	31.10.1992	[3]
Company	:	KOMATSU	
Engine	:	S6D140 / 6211-71-1311	

IP-Type number : 106060-5451 / PE6P
Governor type number : 105407-2901 / EP/RSV

TEST PREREQUISITES

Test oil : ISO-4113
Test oil inlet temperature °C : 40.00...45.00
Inlet pressure bar : 1.6
Test nozzle holder combination : 1 688 901 013
Opening pressure bar : 175
Test pressure line
Inner x Outer Dia - Length mm : 3.00 x 8.00 x 600

PORT CLOSING

Prestroke mm : 4.3 ± 0.05
Rod position mm : -
Port closing mark Cyl. No. : -
Cam sequence : 1-5-3-6-2-4

Port closing mark Cyl. No. : -
Port closing difference °NW : 0-60-120-180-240-300

Tolerance +- °C: 0.50 (0.75)

E10

ZEXEL - Test values
Injection pumps



Injection Quantity :

Adjusting Point	Rack Pos. (mm)	P. Speed (rpm)	Injection Q'ty (cm ³ /1000 str.)	Difference (%)	Fixed	Remarks
A	8.3	1050	133.9 ± 2.0	± 3.0	Lever	Basic
H	approx. 3.5	365	11.5 ± 1.5	± 15.0	Rack	
A	8.3	1050	133.9 ± 2.0	-	Lever	Basic

Timing Advance Specification :

Pump Speed (rpm)						
Advance Angle (deg)						



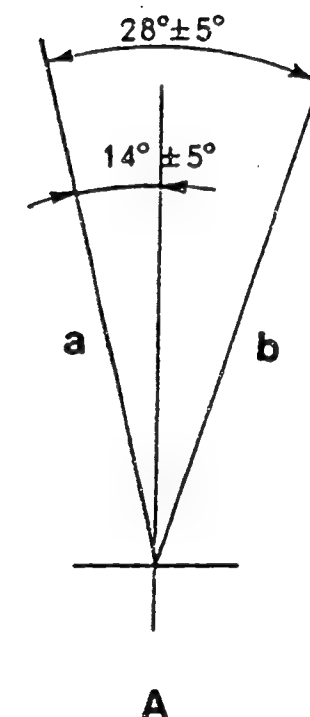
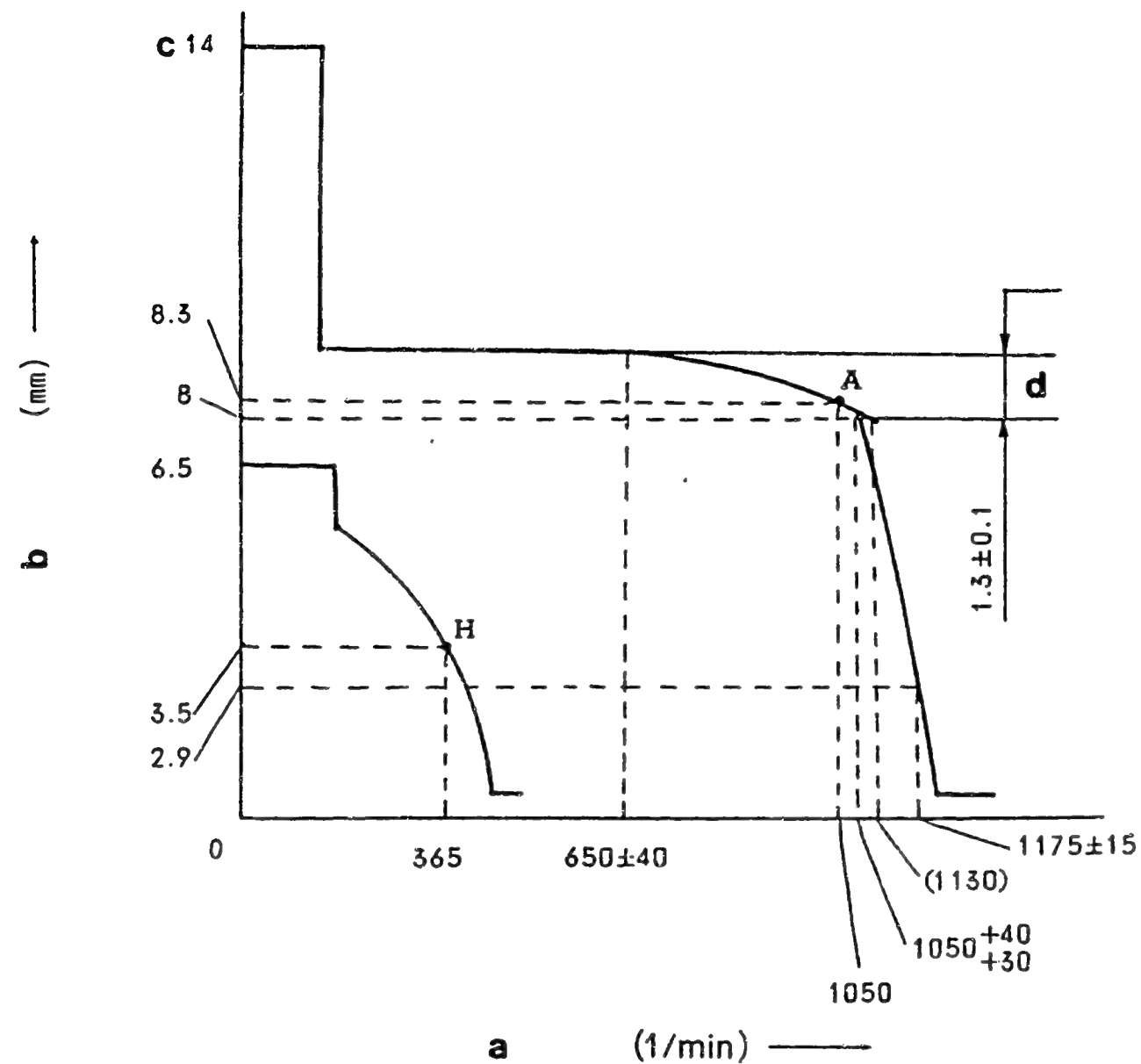

Figure 104

GOVERNOR ADJUSTMENT

106672-9183 2/4

Recommended speed droop adjustment screw position: 16

- a = Pump speed
- b = Control rack position
- c = Above
- d = Difference in control rack position between 1200 rpm and 600 rpm

A = Speed Control Lever Angle

- a = Full-speed
- b = Idling

■ Note

- Before adjustment, remove the idling sub spring.
- Move the control lever fully in the stop direction, and set the minimum-speed stopper bolt so that the control rack position is 0.5 - 1.0 mm.

■ ADJUSTMENT

	Pump speed (rpm)	Rack position (mm)	Remarks
Full-load Adjustment (Temporary)	1200	8.0	<ul style="list-style-type: none"> • Adjust using screw (2) • Adjust using screw (1)
	700	8.0	
Torque Control spring Adjustment	550	9.3	<ul style="list-style-type: none"> • Adjust using spring capsule (4) • Confirm • Confirm the torque control stroke is 1.3 ± 0.1 mm
	650 ± 40	9.3	
	1050	8.3	
	approx. 1130	8.0	
Idling Adjustment	0	6.5	<ul style="list-style-type: none"> • Fix the control lever • Adjust using spring capsule (5) • Confirm
	365	3.5	
Maximum-speed Adjustment	$1050+40$	8.0	<ul style="list-style-type: none"> • Fix the control lever • Confirm speed droop - adjust using screw (3) • Confirm
	$+30$ 1175 ± 15	2.9	
Full-load Adjustment	-	-	<ul style="list-style-type: none"> • Confirm
Control Lever Angle Measurement	<ul style="list-style-type: none"> • Measure the control lever angle at the "idling" and "full" positions. • When the control lever is depressed toward the "full" position, replace the shifter's shim with a thicker one. • When the control lever is depressed toward the "idling" position, replace the shifter's shim with a thinner one. 		
Rack Limiter Adjustment	-	-	<ul style="list-style-type: none"> • Adjust using screw

E15

ZEXEL - Test values

Injection pumps



E16

ZEXEL - Test values

Injection pumps



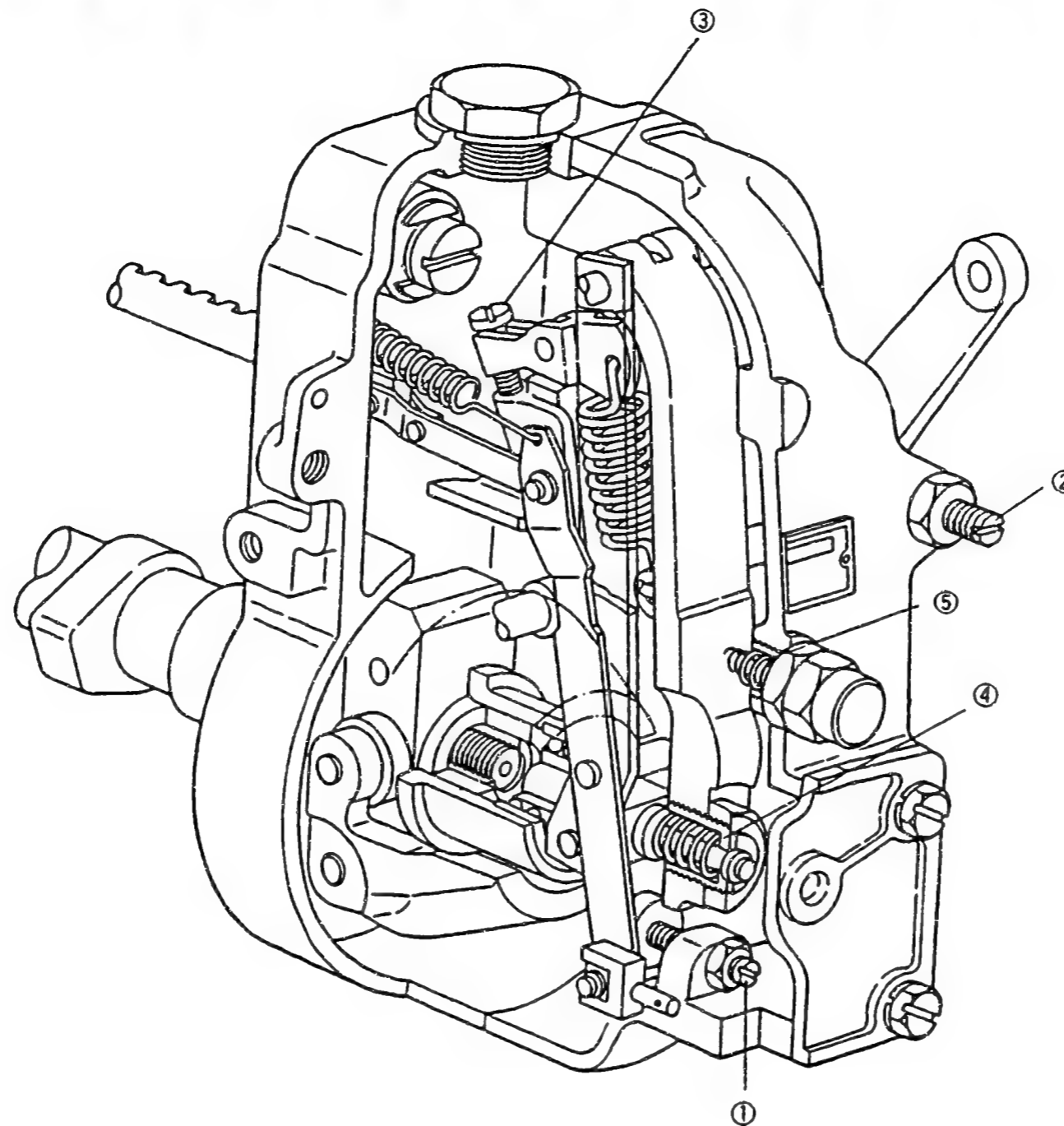

Figure 105

- 1 = Screw
- 2 = Screw
- 3 = Screw
- 4 = Spring capsule
- 5 = Spring capsule

106672-9183 4/4

E17

ZEXEL - Test values
Injection pumps



E18

ZEXEL - Test values
Injection pumps



ZEXEL - TEST VALUES
Injection pumps

BOSCH No.	:	9 400 610 228	1/4
ZEXEL No.	:	106672-9562	
Date	:	31.10.1992	[1]
Company	:	KOMATSU	
Engine	:	S6D140 / 6211-71-1660	

IP-Type number : 106060-7070 / PE 6P
Governor type number : 105447-1250 / EP/RSUV

TEST PREREQUISITES

Test oil : ISO-4113
Test oil inlet temperature °C : 40.00...45.00
Inlet pressure bar : 1.6
Test nozzle holder combination : 0 681 343 002
Opening pressure bar : 175
Test pressure line
Inner x Outer Dia - Length mm : 3.00 x 8.00 x 600

PORT CLOSING

Prestroke mm : 4.3 ± 0.05
Rod position mm : -
Port closing mark Cyl. No. : -
Cam sequence : 1-5-3-6-2-4

Port closing mark Cyl. No. : -
Port closing difference °NW : 0-60-120-180-240-300

Tolerance +- °C: 0.50 (0.75)



Injection Quantity :

Adjusting Point	Rack Pos. (mm)	P. Speed (rpm)	Injection Q'ty (cm ³ /1000 str.)	Difference (%)	Fixed	Remarks
A	11.7	900	268.6 ± 4.0	± 3.0	Lever	Basic
H	approx. 5.8	400	20.7 ± 1.5	± 15.0	Rack	
A	11.7	900	268.6 ± 4.0	-	Lever	Basic

Timing Advance Specification :

Pump Speed (rpm)						
Advance Angle (deg)						



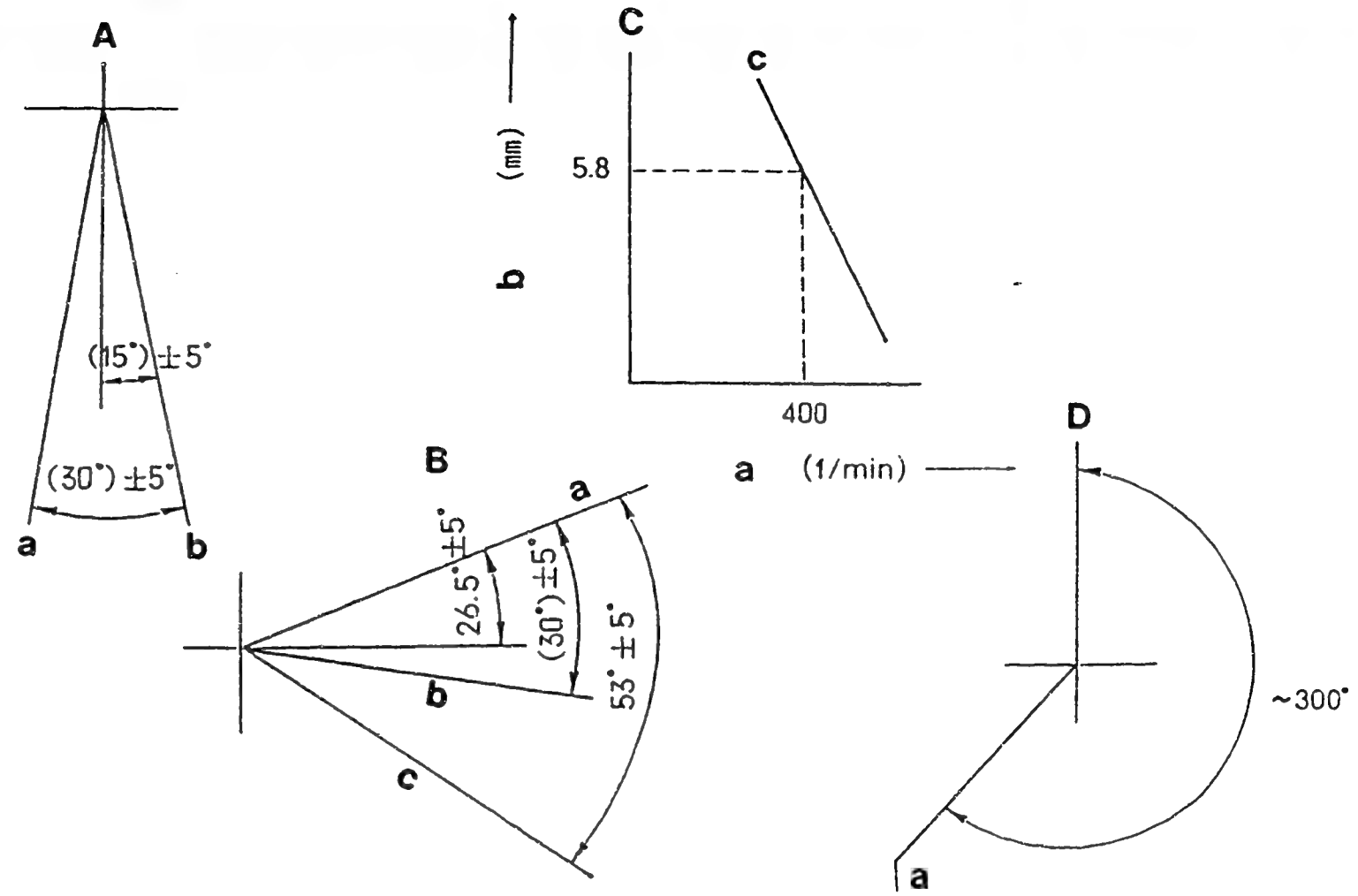
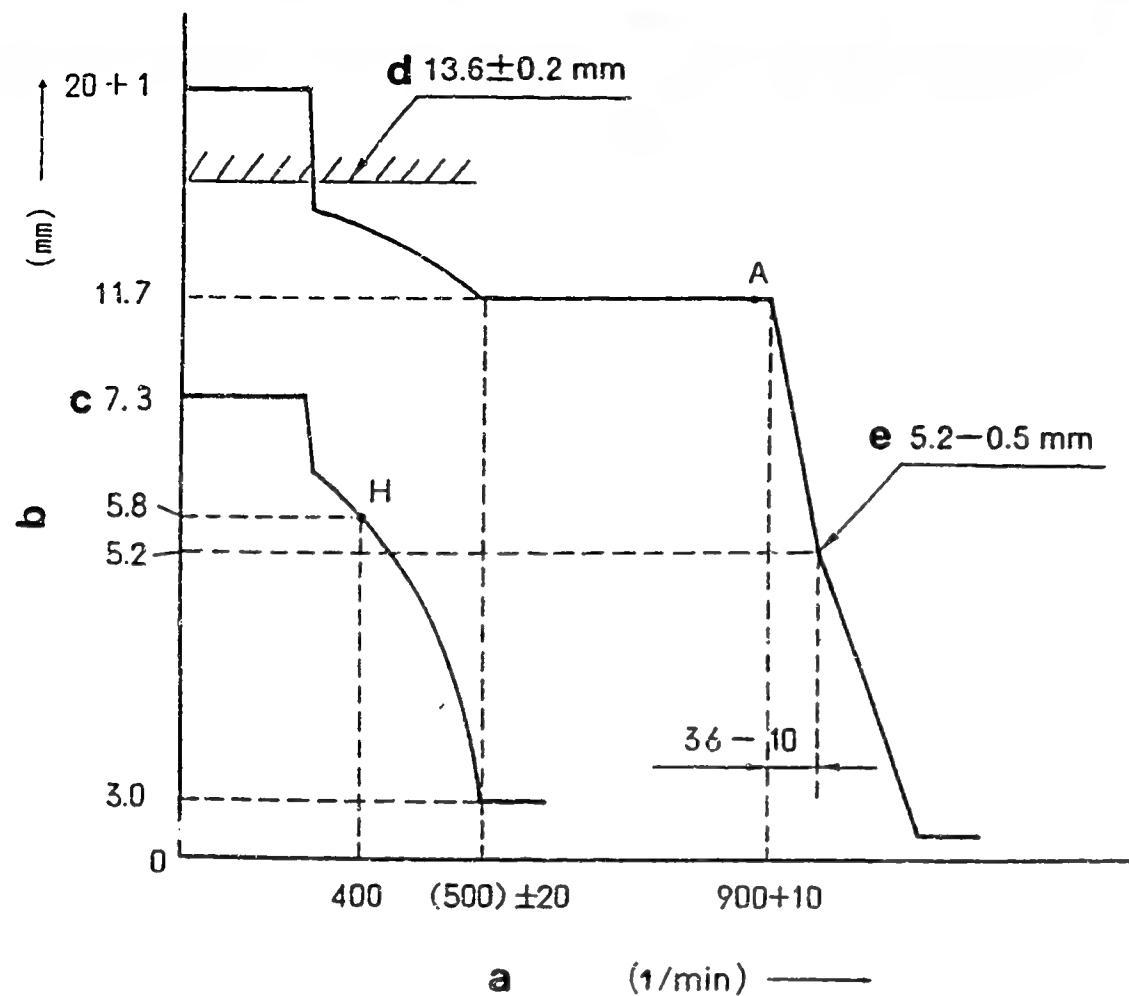

Figure 106

GOVERNOR ADJUSTMENT

106672-9562 2/4

Recommended speed droop adjustment screw position: 17

Minimum-Maximum Speed Specification

- a = Pump speed
- b = Control rack position
- c = Above
- d = Control rack limit:
- e = Idle-sub spring setting:

A = Speed Control Lever Angle

- a = Idling
- b = Full-speed

B = Load-Control Lever Angle

- a = Full-load
- b = Idling
- c = Stop

C = Variable Speed Specification

- a = Pump speed
- b = Control rack position
- c = Idle setting

D = TIMING SETTING

At No. 1 plunger's beginning of injection position.

a = Coupling key groove position

■ Note

- Before adjustment, remove the idling sub spring.
- Move the control lever fully in the stop direction, and set the minimum-speed stopper bolt so that the control rack position is 0.5 - 1.0 mm.

■ ADJUSTMENT

		Pump Speed (rpm)	Rack Position (mm)	Boost pressure kPa (mmHg)	Remarks
Full-load Adjustment (Temporary)		1100 700	11.7 11.7	-	<ul style="list-style-type: none"> • Adjust using screw (2) • Adjust using screw (1)
Torque Control Spring Adjust- ment	1.st stroke	approx. 500	11.7	-	<ul style="list-style-type: none"> • Adjust using spring capsule (4) • Confirm • Confirm the torque control stroke is: (mm)
	2.st stroke	-	-	-	<ul style="list-style-type: none"> • Adjust using spring capsule (4) • Confirm • Confirm the torque control stroke is: (mm)
Maximum-speed Adjustment		900 + 10 900+36 +26	11.7 5.2	-	<ul style="list-style-type: none"> • Fix the control lever • Confirm speed droop - adjust using screw (3) • Confirm
Boost Compensator System		-	-	-	<ul style="list-style-type: none"> • Fix the control lever • Adjust using screw (6) • Confirm the boost compensator stroke is: (mm)
Idling Adjustment		0	7.3	-	<ul style="list-style-type: none"> • Fix the control lever • Adjust using spring capsule (5) • Confirm
1. Idling Sub Spring		900+36 +26 above 550	5.2 3.0		
2. Control Lever	H	400	5.8	-	
Full-load Adjustment		-	-	-	<ul style="list-style-type: none"> • Confirm
Control Lever Angle Measurement		<ul style="list-style-type: none"> • Measure the control lever angle at the "idling" and "full" positions. • When the control lever is depressed toward the "full" position, replace the shifter's shim with a thicker one. • When the control lever is depressed toward the "idling" position, replace the shifter's shim with a thinner one. 			
Control Rack Limiter Adjustment		0	13.6 ± 0.2	-	<ul style="list-style-type: none"> • Adjust using screw

E24

ZEXEL - Test values
Injection pumps



E25

ZEXEL - Test values
Injection pumps



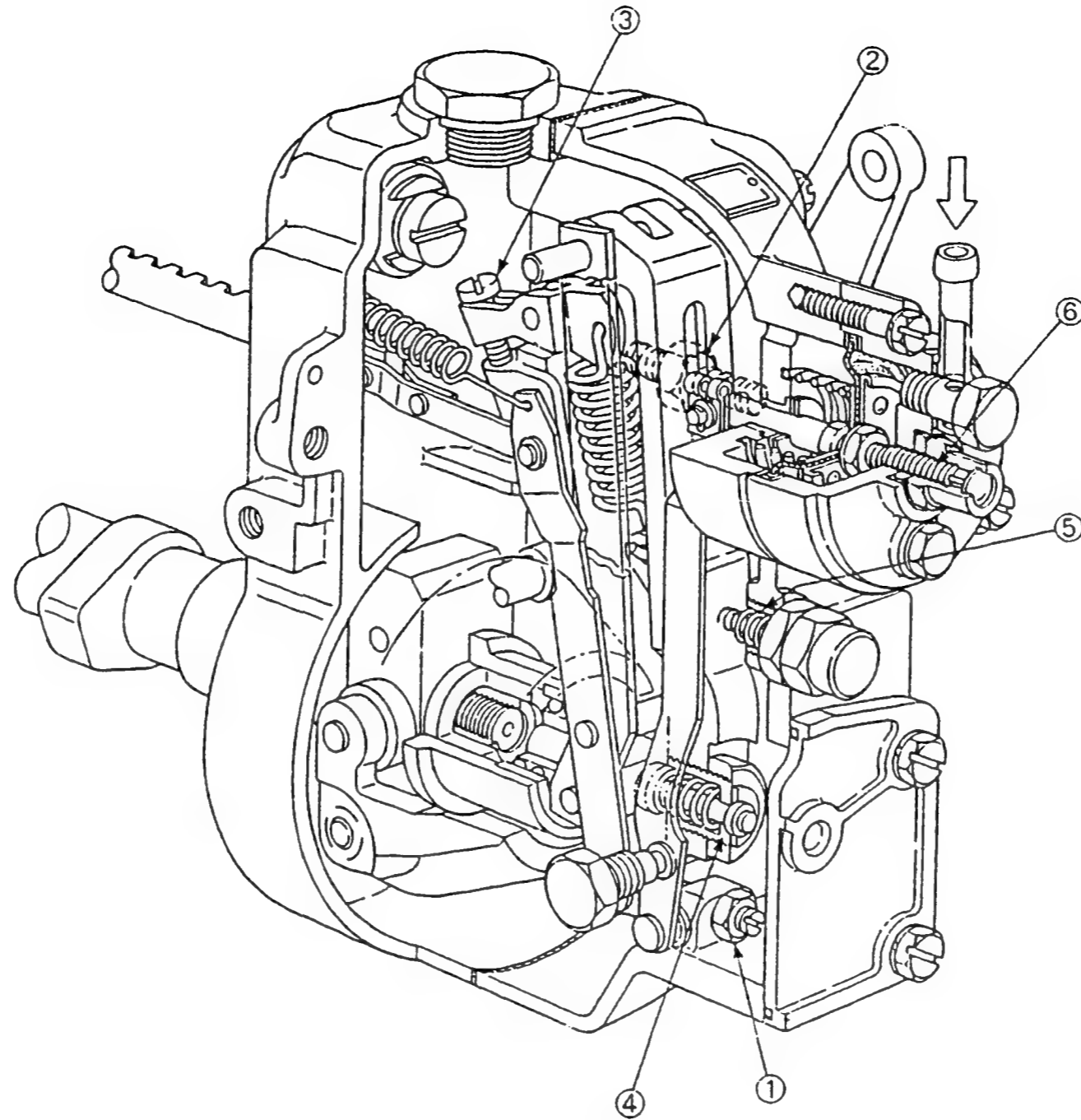

Figure 107

- 1 = Screw
- 2 = Screw
- 3 = Screw
- 4 = Spring capsule
- 5 = Spring capsule
- 6 = Screw

106672-9562 4/4

E26

ZEXEL - Test values
Injection pumps



E27

ZEXEL - Test values
Injection pumps



ZEXEL - TEST VALUES
Injection pumps

BOSCH No.	:	9 400 610 230	1/4
ZEXEL No.	:	106692-4123	
Date	:	31.10.1992	[4]
Company	:	KOMATSU	
Engine	:	SA6D170 / 6162-73-1253	

IP-Type number : 106069-8031 / PES6PD
Governor type number : 105448-9502 / EP/RSUV

TEST PREREQUISITES

Test oil : ISO-4113
Test oil inlet temperature °C : 40.00...45.00
Inlet pressure bar : 1.6
Test nozzle holder combination : 0 681 343 002
Opening pressure bar : 175
Test pressure line
Inner x Outer Dia - Length mm : 3.00 x 8.00 x 600

PORT CLOSING

Prestroke mm : 2.4 ± 0.05
Rod position mm : -
Port closing mark Cyl. No. : -
Cam sequence : 1-5-3-6-2-4

Port closing mark Cyl. No. : -
Port closing difference °NW : 0-60-120-180-240-300

Tolerance +- °C: 0.50 (0.75)

F1

ZEXEL - Test values
Injection pumps



Injection Quantity :

Adjusting Point	Rack Pos. (mm)	P. Speed (rpm)	Injection Q'ty (cm ³ /1000 str.)	Difference (%)	Fixed	Remarks
A	14.5	900	472.5 ± 5.0	-	Lever	Basic
H	approx. 5.4	400	39.5 ± 5.0	± 10	Rack	
A	14.5	900	472.5 ± 5.0	-	Lever	Basic

Timing Advance Specification :

Pump Speed (rpm)						
Advance Angle (deg)						

■ Note

- Before adjustment, remove the idling sub spring.
- Move the control lever fully in the stop direction, and set the minimum-speed stopper bolt so that the control rack position is 0.5 - 1.0 mm.

■ ADJUSTMENT

		Pump Speed (rpm)	Rack Position (mm)	Boost pressure kPa (mmHg)	Remarks
Full-load Adjustment (Temporary)		1100 700	14.5 14.5	-	<ul style="list-style-type: none"> • Adjust using screw (2) • Adjust using screw (1)
Torque Control Spring Adjust- ment	1.st stroke	-	-	-	<ul style="list-style-type: none"> • Adjust using spring capsule (4) • Confirm • Confirm the torque control stroke is: (mm)
	2.st stroke	-	-	-	<ul style="list-style-type: none"> • Adjust using spring capsule (4) • Confirm • Confirm the torque control stroke is: (mm)
Maximum-speed Adjustment		900 ± 10 below 945	14.5 5.3	-	<ul style="list-style-type: none"> • Fix the control lever • Confirm speed droop - adjust using screw (3) • Confirm
Boost Compensator System		-	-	-	<ul style="list-style-type: none"> • Fix the control lever • Adjust using screw (6) • Confirm the boost compensator stroke is: (mm)
Idling Adjustment					
1. Idling Sub Spring		below 945	5.3 -0.5	-	<ul style="list-style-type: none"> • Fix the control lever • Adjust using spring capsule (5) • Confirm
2. Control Lever	H	0 400 above 500	above 6.9 5.4 0.5	-	<ul style="list-style-type: none"> • Adjust using the control lever • Confirm
Full-load Adjustment		900	14.5	-	<ul style="list-style-type: none"> • Confirm
Control Lever Angle Measurement		<ul style="list-style-type: none"> • Measure the control lever angle at the "idling" and "full" positions. • When the control lever is depressed toward the "full" position, replace the shifter's shim with a thicker one. • When the control lever is depressed toward the "idling" position, replace the shifter's shim with a thinner one. 			
Control Rack Limiter Adjustment		0	16 + 0.2	-	<ul style="list-style-type: none"> • Adjust using screw

F6

ZEXEL - Test values
Injection pumps



F7

ZEXEL - Test values
Injection pumps



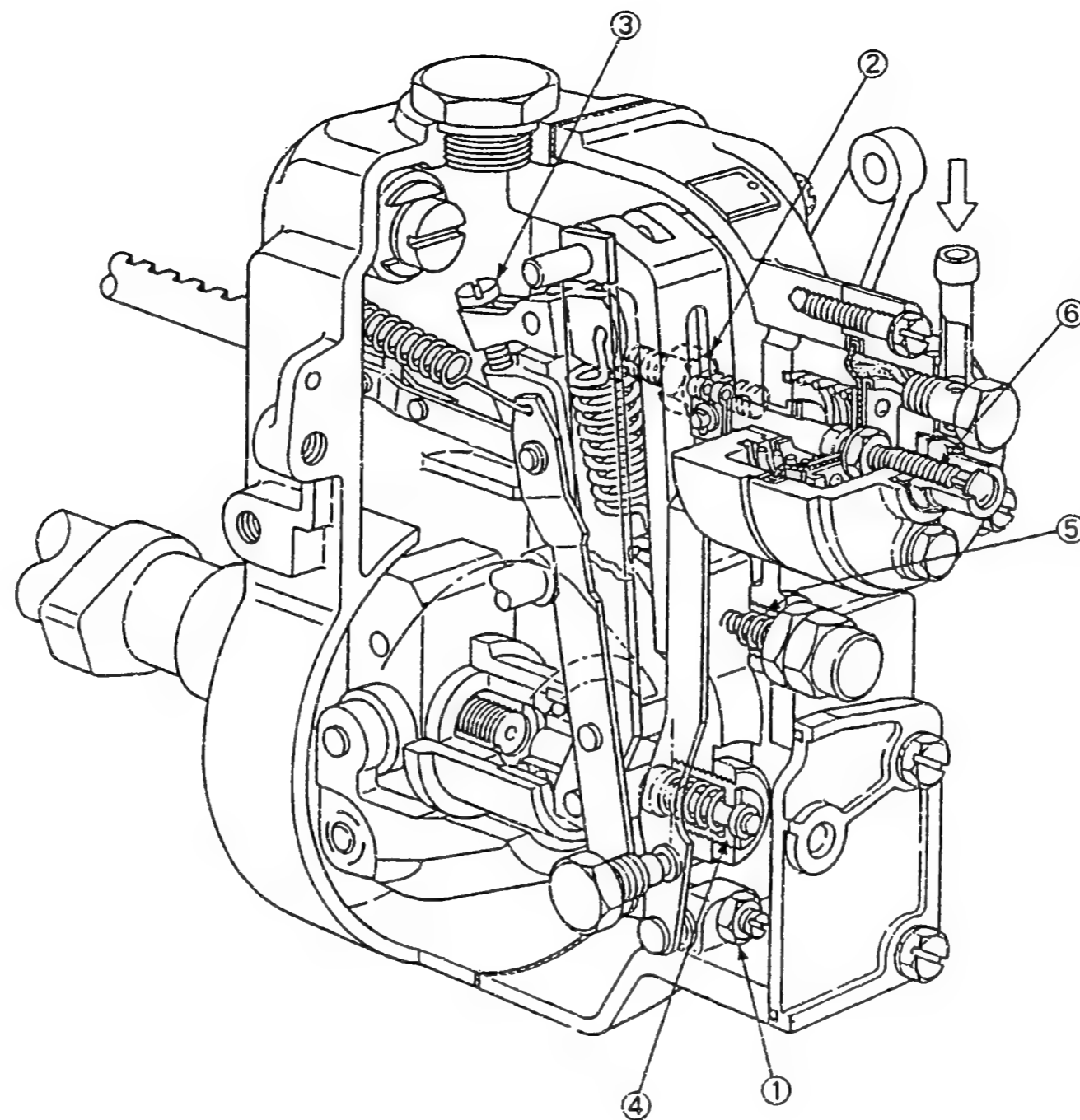

Figure 109

- 1 = Screw
- 2 = Screw
- 3 = Screw
- 4 = Spring capsule
- 5 = Spring capsule
- 6 = Screw

106692-4123 3/4

F8

ZEXEL - Test values
Injection pumps



F9

ZEXEL - Test values
Injection pumps



ZEXEL - TEST VALUES
Injection pumps

BOSCH No.	:	9 400 610 231	1/4
ZEXEL No.	:	106692-4323	
Date	:	31.10.1992	[5]
Company	:	KOMATSU	
Engine	:	S6D125 / 6151-71-1220	

IP-Type number : 106069-5540 / PE 6P
Governor type number : 105407-2822 / EP/RSV

TEST PREREQUISITES

Test oil : ISO-4113
Test oil inlet temperature °C : 40.00...45.00
Inlet pressure bar : 1.6
Test nozzle holder combination : 1 688 901 013
Opening pressure bar : 175
Test pressure line
Inner x Outer Dia - Length mm : 3.00 x 8.00 x 600

PORT CLOSING

Prestroke mm : 3.75 ± 0.05
Rod position mm : -
Port closing mark Cyl. No. : -
Cam sequence : 1-5-3-6-2-4

Port closing mark Cyl. No. : -
Port closing difference °NW : 0-60-120-180-240-300

Tolerance +- °C: 0.50 (0.75)

F10

ZEXEL - Test values
Injection pumps



Continued (Test values)

Injection Quantity :

Adjusting Point	Rack Pos. (mm)	P. Speed (rpm)	Injection Q'ty (cm ³ /1000 str.)	Difference (%)	Fixed	Remarks
A	9.6	1000	141.8 ± 2.0	± 3	Lever	Basic
H	approx. 6.5	325	11.0 ± 1.5	± 15	Rack	
A	9.6	1000	141.8 ± 2.0	-	Lever	Basic

Timing Advance Specification :

Pump Speed (rpm)						
Advance Angle (deg)						

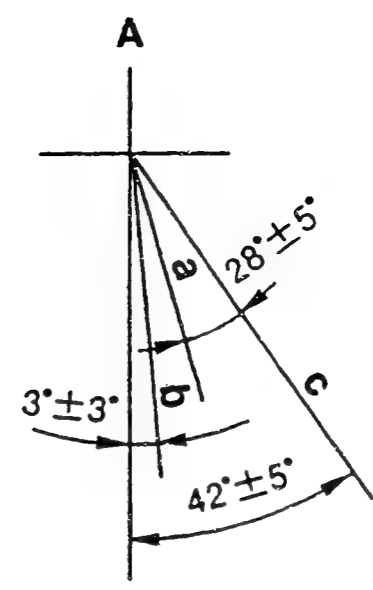
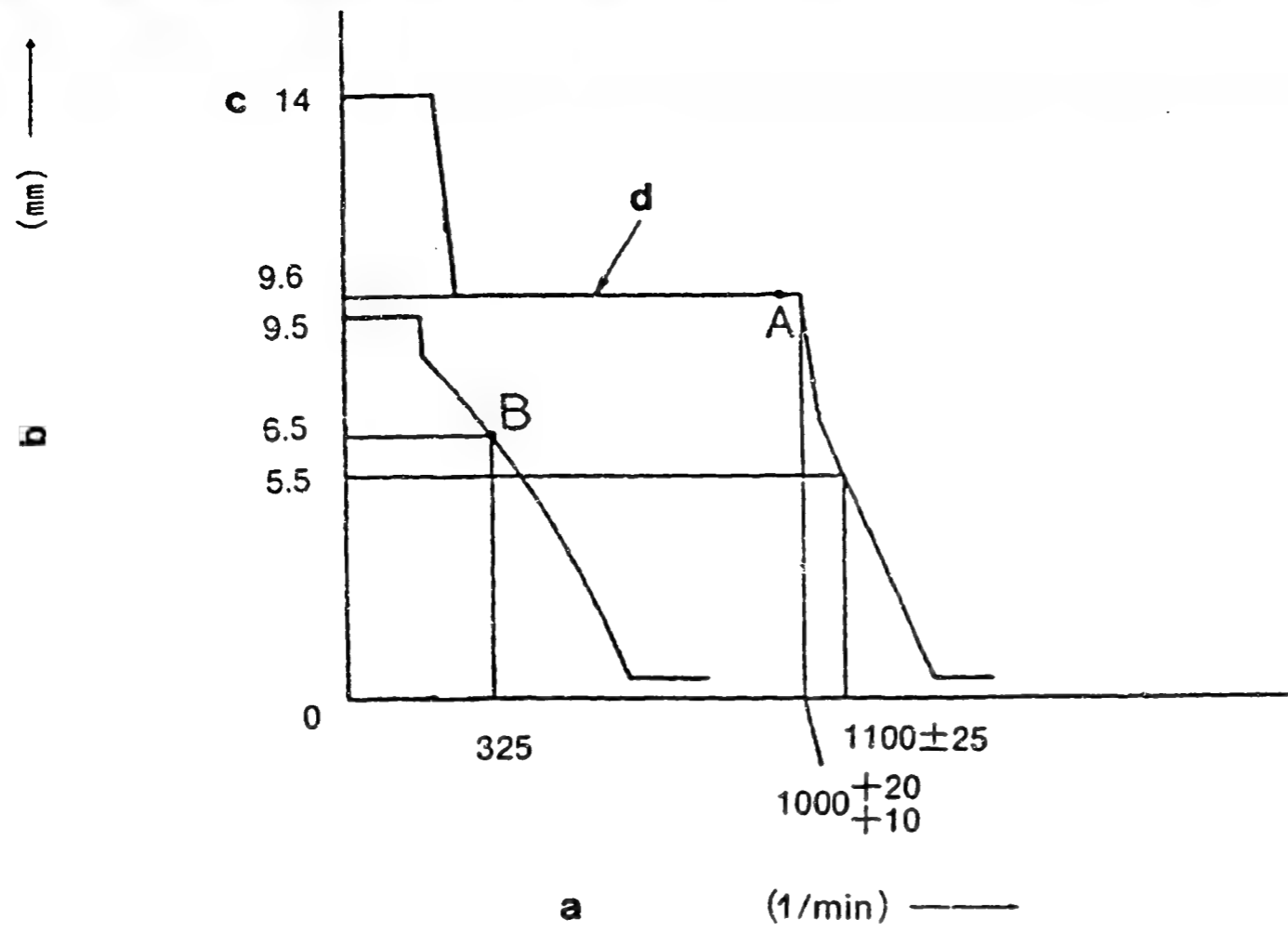

Figure 110

GOVERNOR ADJUSTMENT

106692-4323 2/4

Recommended speed droop adjustment screw position: 16

- a = Pump speed
- b = Control rack position
- c = Above
- d = Perform torque control spring adjustment when necessary

- A = Speed Control Lever Angle
- a = Idling
- b = Stop
- c = Full-speed

■ Note

- Before adjustment, remove the idling sub spring.
- Move the control lever fully in the stop direction, and set the minimum-speed stopper bolt so that the control rack position is 0.5 - 1.0 mm.

■ ADJUSTMENT

	Pump speed (rpm)	Rack position (mm)	Remarks
Full-load Adjustment (Temporary)	1200 700	9.6 9.6	<ul style="list-style-type: none"> • Adjust using screw (2) • Adjust using screw (1)
Torque Control spring Adjustment	-	-	<ul style="list-style-type: none"> • Adjust using spring capsule (4) • Confirm • Confirm the torque control stroke is: (mm)
Idling Adjustment	0 325	9.5 6.5	<ul style="list-style-type: none"> • Fix the control lever • Adjust using spring capsule (5) • Confirm
Maximum-speed Adjustment	1000+20 +10 1100±25	9.6 5.5	<ul style="list-style-type: none"> • Fix the control lever • Confirm speed droop - adjust using screw (3) • Confirm
Full-load Adjustment	1000	9.6	<ul style="list-style-type: none"> • Confirm
Control Lever Angle Measurement	<ul style="list-style-type: none"> • Measure the control lever angle at the "idling" and "full" positions. • When the control lever is depressed toward the "full" position, replace the shifter's shim with a thicker one. • When the control lever is depressed toward the "idling" position, replace the shifter's shim with a thinner one. 		
Rack Limiter Adjustment	-	-	<ul style="list-style-type: none"> • Adjust using screw

F15

ZEXEL - Test values
Injection pumps



F16

ZEXEL - Test values
Injection pumps



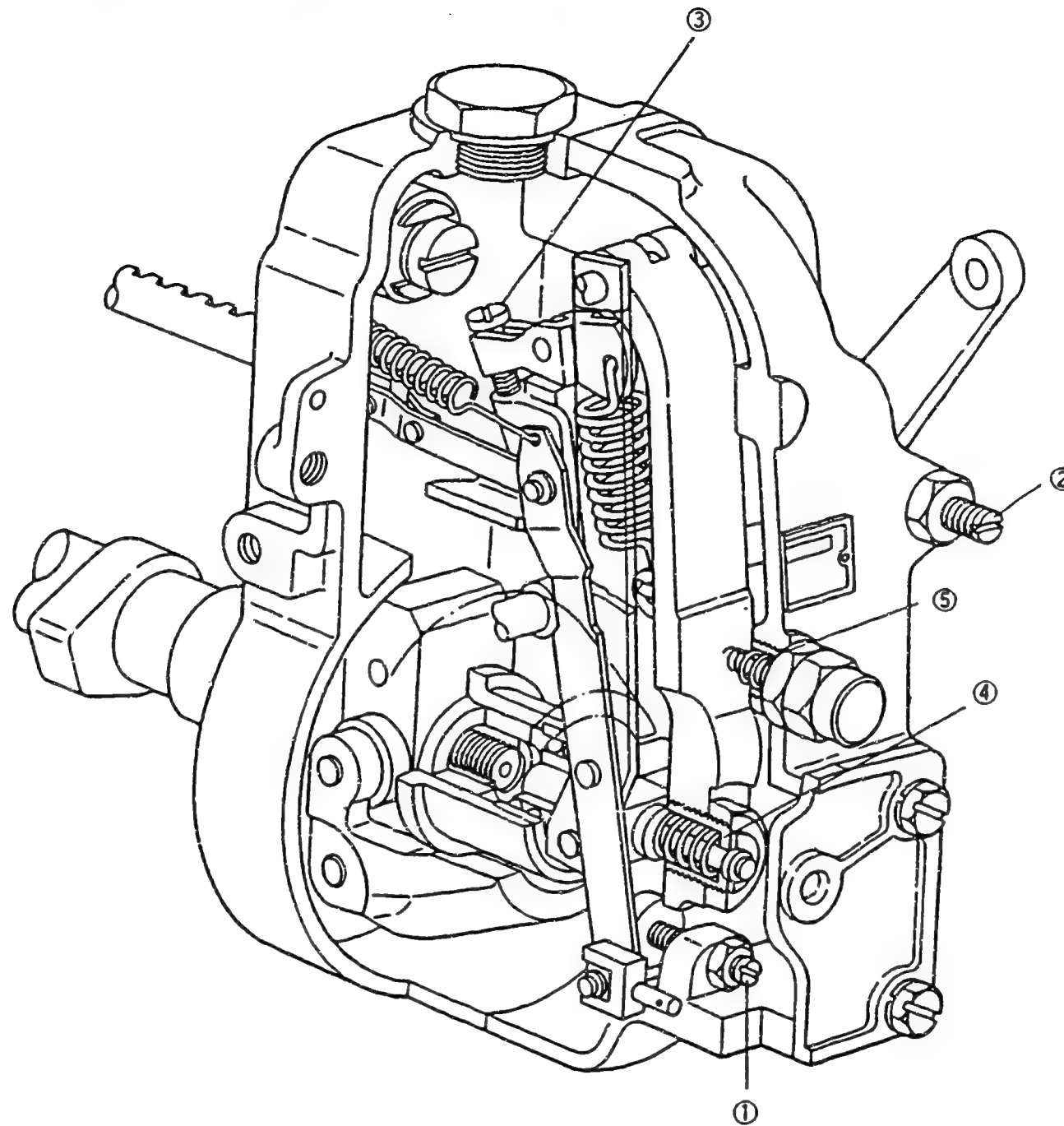

Figure 111

- 1 = Screw
- 2 = Screw
- 3 = Screw
- 4 = Spring capsule
- 5 = Spring capsule

106692-4323 4/4

F17

ZEXEL - Test values
Injection pumps



F18

ZEXEL - Test values
Injection pumps



ZEXEL - TEST VALUES
Injection pumps

BOSCH No.	:	9 400 610 234	1/4
ZEXEL No.	:	106692-4403	
Date	:	31.10.1992	[0]
Company	:	KOMATSU	
Engine	:	S6D125 / 6151-71-1112	

IP-Type number : 106069-5420 / PE 6P
Governor type number : 105407-2961 / EP/RSV

TEST PREREQUISITES

Test oil : ISO-4113
Test oil inlet temperature °C : 40.00...45.00
Inlet pressure bar : 1.6
Test nozzle holder combination : 1 688 901 013
Opening pressure bar : 175
Test pressure line
Inner x Outer Dia - Length mm : 3.00 x 8.00 x 600

PORT CLOSING

Prestroke mm : 3.75 ± 0.05
Rod position mm : -
Port closing mark Cyl. No. : -
Cam sequence : 1-5-3-6-2-4

Port closing mark Cyl. No. : -
Port closing difference °NW : 0-60-120-180-240-300

Tolerance +- °C: 0.50 (0.75)



Injection Quantity :

Adjusting Point	Rack Pos. (mm)	P. Speed (rpm)	Injection Q'ty (cm ³ /1000 str.)	Difference (%)	Fixed	Remarks
A	9.1	1100	120.8 ± 2.0	± 3.0	Lever	Basic
H	approx. 6.5	350	12.3 ± 1.5	± 15.0	Rack	
A	9.1	1100	120.8 ± 2.0	-	Lever	Basic

Timing Advance Specification :

Pump Speed (rpm)					
Advance Angle (deg)					

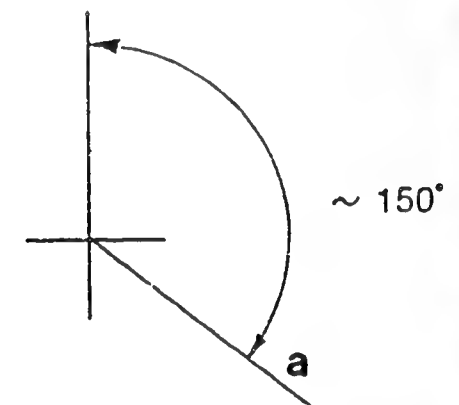
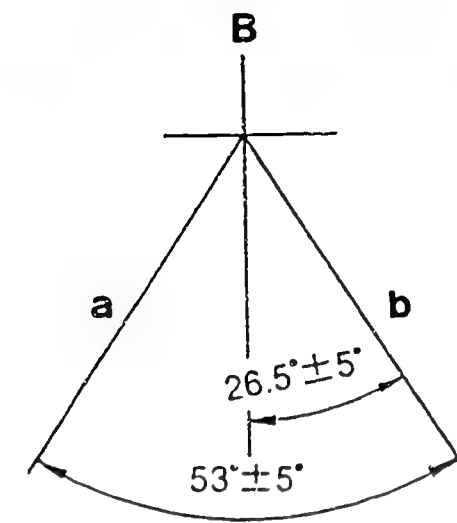
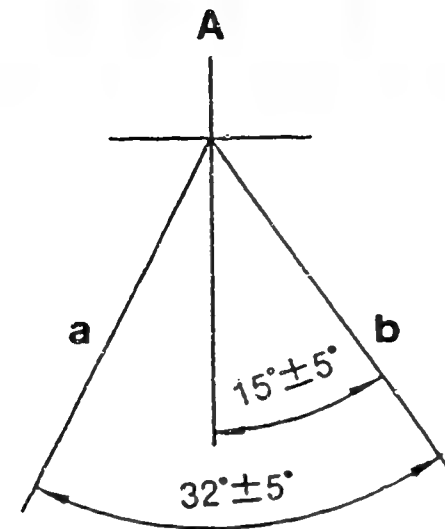
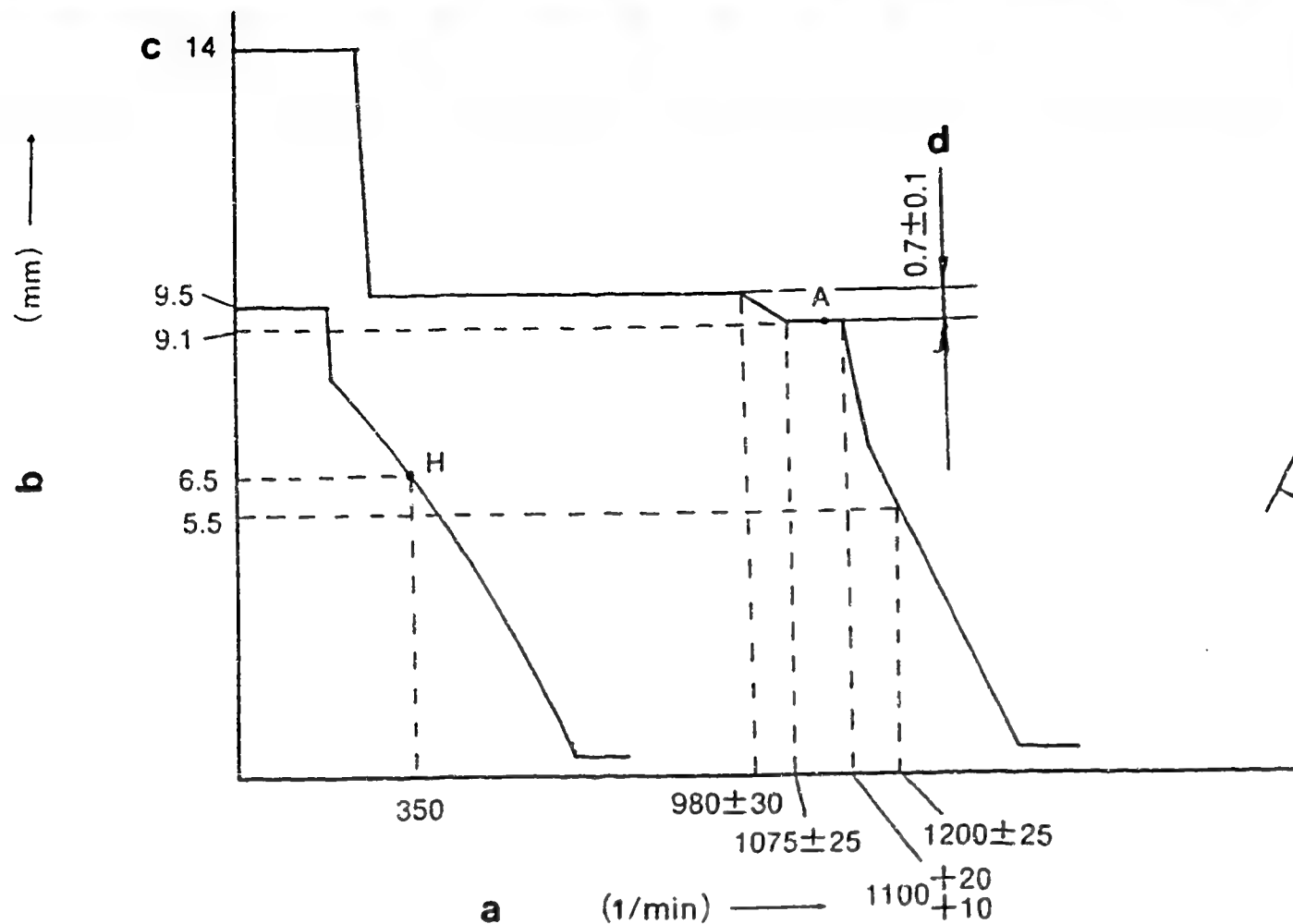

Figure 112

GOVERNOR ADJUSTMENT

Recommended speed droop adjustment screw position: 17

106692-4403 2/4

- a = Pump speed
- b = Control rack position
- c = Above
- d = Difference in control rack position between 1100 rpm and 700 rpm

A = Speed Control Lever Angle

- a = Idling
- b = Full-speed

B = Stop Lever Angle

- a = Stop
- b = Normal

■ TIMING SETTING

At No. 1 plunger's beginning of injection position.

a = Coupling key groove position

F22

ZEXEL - Test values
Injection pumps



F23

ZEXEL - Test values
Injection pumps



■ Note

- Before adjustment, remove the idling sub spring.
- Move the control lever fully in the stop direction, and set the minimum-speed stopper bolt so that the control rack position is 0.5 - 1.0 mm.

■ ADJUSTMENT

		Pump Speed (rpm)	Rack Position (mm)	Boost pressure kPa (mmHg)	Remarks
Full-load Adjustment (Temporary)		1300 700	9.1 9.1	-	<ul style="list-style-type: none"> • Adjust using screw (2) • Adjust using screw (1)
Torque Control Spring Adjust- ment	1.st stroke	880 980 ± 30 1075 ± 25	9.8 9.8 9.1	-	<ul style="list-style-type: none"> • Adjust using spring capsule (4) • Confirm • Confirm the torque control stroke is: 0.7 ± 0.1 mm
	2.st stroke	-	-	-	<ul style="list-style-type: none"> • Adjust using spring capsule (4) • Confirm • Confirm the torque control stroke is: (mm)
Maximum Speed Adjustment		1100+20 +10 1200±25	9.1 5.5	-	<ul style="list-style-type: none"> • Fix the control lever • Confirm speed droop - adjust using screw (3) • Confirm
Boost Compensator System		-	-	-	<ul style="list-style-type: none"> • Fix the control lever • Adjust using screw (6) • Confirm the boost compensator stroke is: (mm)
Idling Adjustment		0	9.5	-	<ul style="list-style-type: none"> • Adjust using the control lever
1. Idling Sub Spring	H	365	6.5	-	<ul style="list-style-type: none"> • Adjust using spring capsule (5) • Confirm
2. Control Lever		-	-	-	<ul style="list-style-type: none"> • Adjust using the control lever
Full-load Adjustment		1100	9.1	-	<ul style="list-style-type: none"> • Confirm
Control Lever Angle Measurement		<ul style="list-style-type: none"> • Measure the control lever angle at the "idling" and "full" positions. • When the control lever is depressed toward the "full" position, replace the shifter's shim with a thicker one. • When the control lever is depressed toward the "idling" position, replace the shifter's shim with a thinner one. 			
Control Rack Limiter Adjustment		-	-	-	<ul style="list-style-type: none"> • Adjust using screw

F24

ZEXEL - Test values
Injection pumps



F25

ZEXEL - Test values
Injection pumps



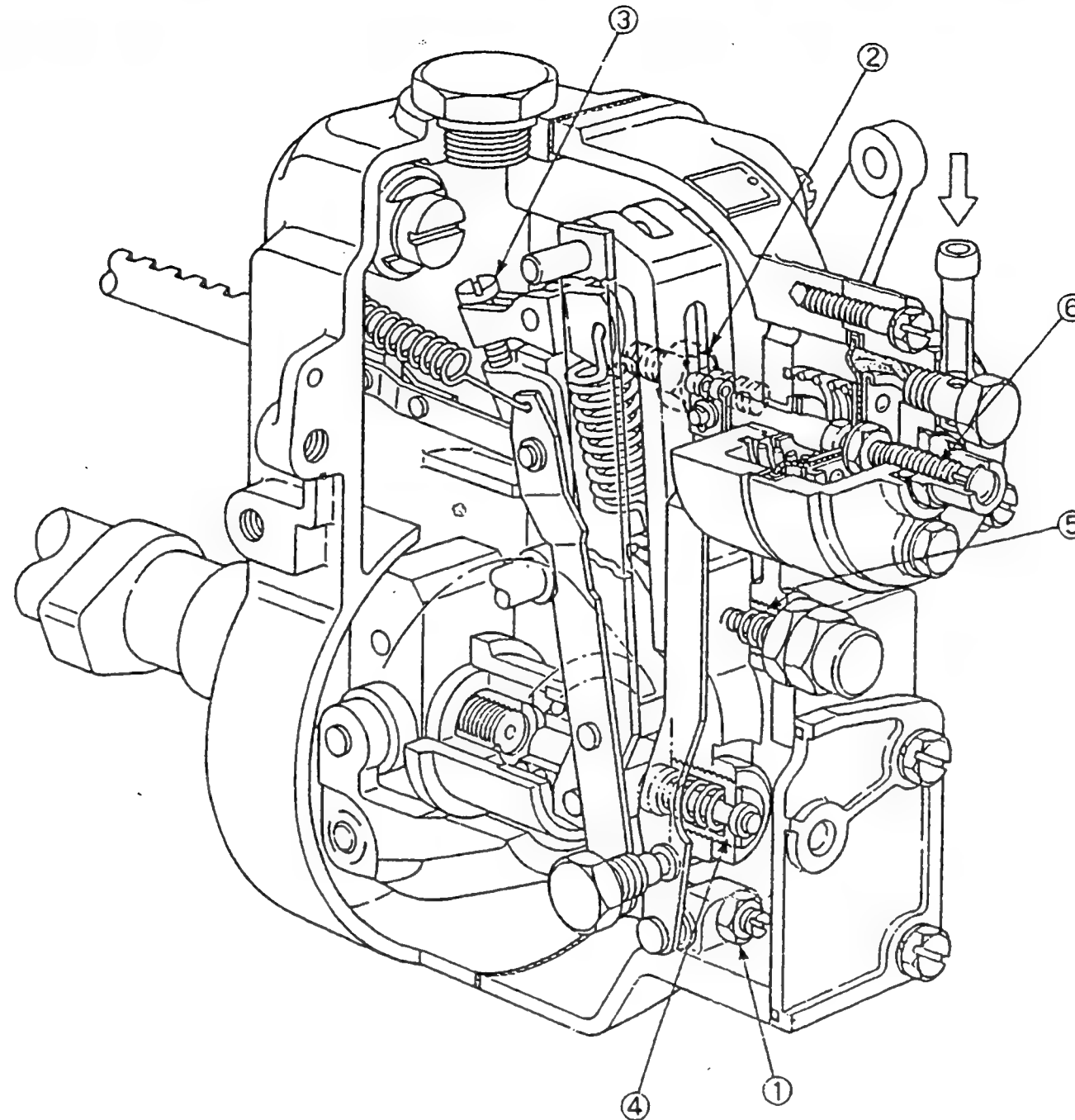

Figure 113

- 1 = Screw
- 2 = Screw
- 3 = Screw
- 4 = Spring capsule
- 5 = Spring capsule
- 6 = Screw

106692-4403 4/4

F26

ZEXEL - Test values
Injection pumps



F27

ZEXEL - Test values
Injection pumps



ZEXEL - TEST VALUES
Injection pumps

BOSCH No.	:	9 400 610 235	1/4
ZEXEL No.	:	106692-4593	
Date	:	31.10.1992	[0]
Company	:	KOMATSU	
Engine	:	S6D125 / 6151-71-1410	

IP-Type number : 106069-5420 / PE 6P
Governor type number : 105407-3363 / EP/RSV

TEST PREREQUISITES

Test oil : ISO-4113
Test oil inlet temperature °C : 40.00...45.00
Inlet pressure bar : 1.6
Test nozzle holder combination : 1 688 901 013
Opening pressure bar : 175
Test pressure line
Inner x Outer Dia - Length mm : 3.00 x 8.00 x 600

PORT CLOSING

Prestroke mm : 3.75 ± 0.05
Rod position mm : -
Port closing mark Cyl. No. : -
Cam sequence : 1-5-3-6-2-4

Port closing mark Cyl. No. : -
Port closing difference °NW : 0-60-120-180-240-300

Tolerance +- °C: 0.50 (0.75)

G1

ZEXEL - Test values
Injection pumps



Injection Quantity :

Adjusting Point	Rack Pos. (mm)	P. Speed (rpm)	Injection Q'ty (cm ³ /1000 str.)	Difference (%)	Fixed	Remarks
A	9.1	1100	120.8 ± 2.0	± 3.0	Lever	Basic
H	approx. 6.5	350	12.3 ± 1.5	± 15.0	Rack	
A	9.1	1100	120.8 ± 2.0	-	Lever	Basic

Timing Advance Specification :

Pump Speed (rpm)					
Advance Angle (deg)					

G2

ZEXEL - Test values

Injection pumps



G3

ZEXEL - Test values

Injection pumps



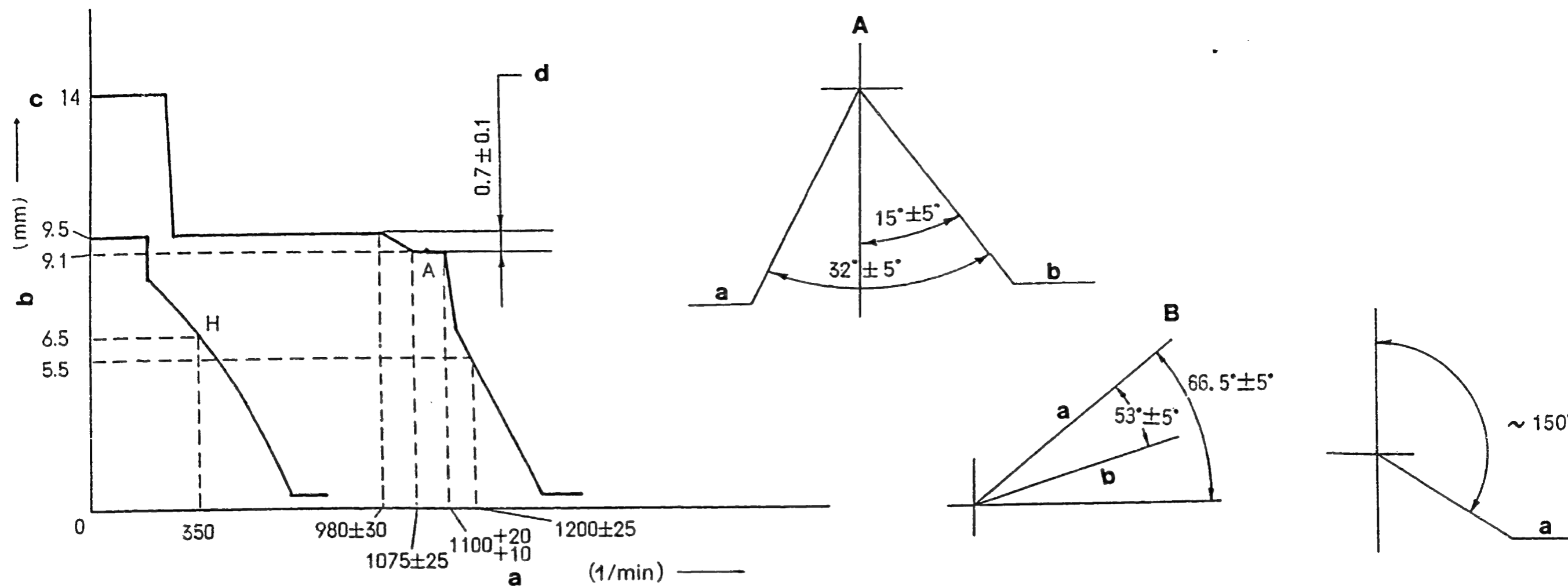

Figure 114

GOVERNOR ADJUSTMENT

Recommended speed droop adjustment screw position: 17

106692-4593 2/4

- a = Pump speed
- b = Control rack position
- c = Above
- d = Difference in control rack position between 1100 rpm and 700 rpm

A = Speed Control Lever Angle

- a = Idling
- b = Full-speed

B = Stop Lever Angle

- a = Normal
- b = Stop

■ TIMING SETTING

At No. 1 plunger's beginning of injection position.

a = Coupling key groove position

G4

ZEXEL - Test values
Injection pumps



G5

ZEXEL - Test values
Injection pumps



■ Note

- Before adjustment, remove the idling sub spring.
- Move the control lever fully in the stop direction, and set the minimum-speed stopper bolt so that the control rack position is 0.5 - 1.0 mm.

■ ADJUSTMENT

	Pump speed (rpm)	Rack position (mm)	Remarks
Full-load Adjustment (Temporary)	1300	9.1	<ul style="list-style-type: none"> • Adjust using screw (2) • Adjust using screw (1)
	700	9.1	
Torque Control spring Adjustment	approx. 880	9.8	<ul style="list-style-type: none"> • Adjust using spring capsule (4) • Confirm • Confirm the torque control stroke is 0.7 ± 0.1 mm
	980 ± 30	9.8	
	1075 ± 25	9.1	
Idling Adjustment	0	9.5	<ul style="list-style-type: none"> • Fix the control lever • Adjust using spring capsule (5) • Confirm
	350	6.5	
Maximum-speed Adjustment	1100+20	9.1	<ul style="list-style-type: none"> • Fix the control lever • Confirm speed droop - adjust using screw (3) • Confirm
	+10 1200 ± 25	5.5	
Full-load Adjustment	1100	9.1	<ul style="list-style-type: none"> • Confirm
Control Lever Angle Measurement	<ul style="list-style-type: none"> • Measure the control lever angle at the "idling" and "full" positions. • When the control lever is depressed toward the "full" position, replace the shifter's shim with a thicker one. • When the control lever is depressed toward the "idling" position, replace the shifter's shim with a thinner one. 		
Rack Limiter Adjustment	-	-	<ul style="list-style-type: none"> • Adjust using screw

G6

ZEXEL - Test values

Injection pumps



G7

ZEXEL - Test values

Injection pumps



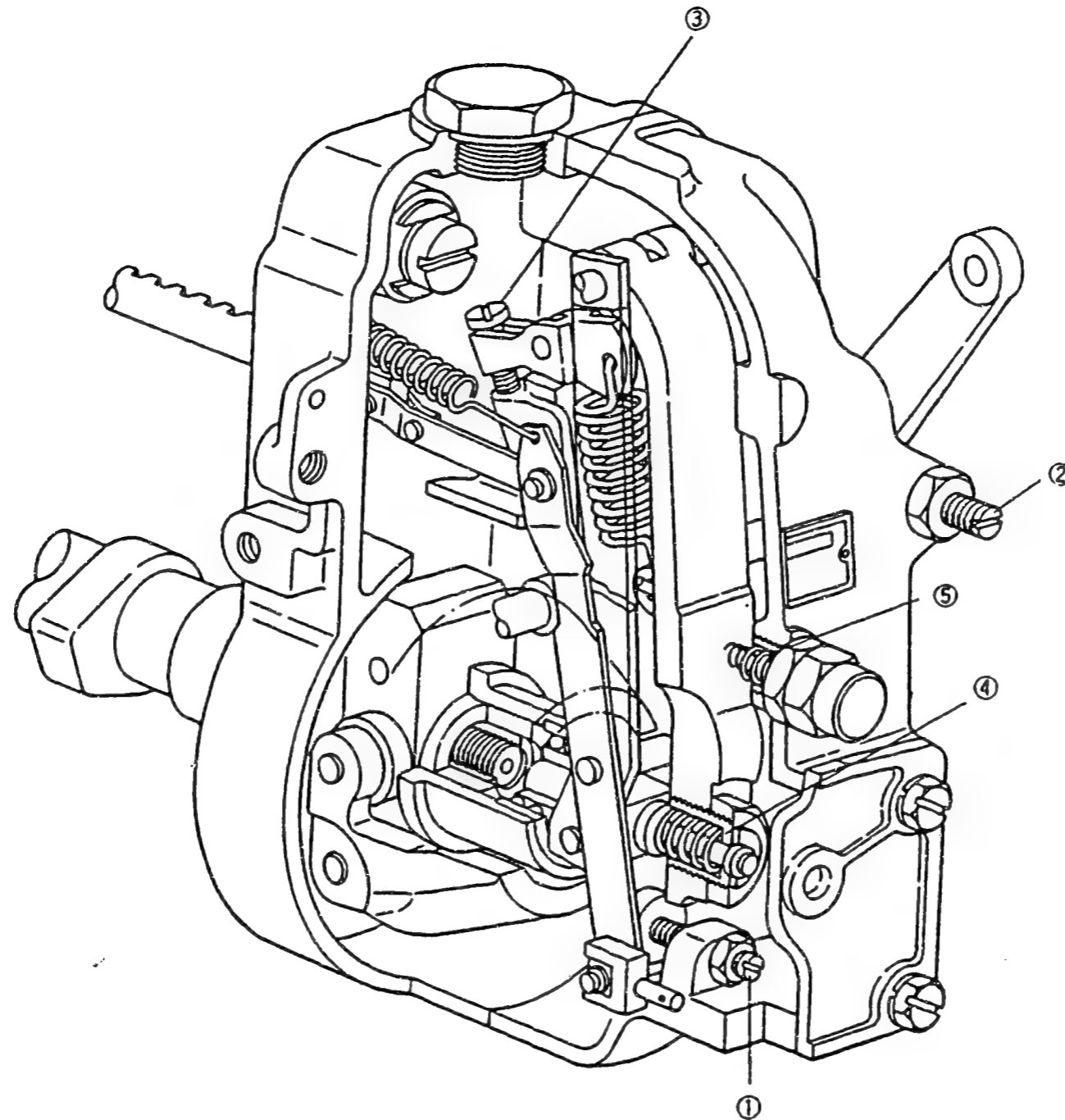

Figure 115

- 1 = Screw
- 2 = Screw
- 3 = Screw
- 4 = Spring capsule
- 5 = Spring capsule

106692-4593 4/4

G8

ZEXEL - Test values
Injection pumps



G9

ZEXEL - Test values
Injection pumps



ZEXEL - TEST VALUES.

Injection pumps

BOSCH No.	: 9 400 610 236	1/4
ZEXEL No.	: 106692-4633	
Date	: 31.10.1992	[2]
Company	: KOMATSU	
Engine	: S6D125 / 6151-71-1150	

IP-Type number : 106069-5420 / PE 6P
 Governor type number : 105407-3711 / EP/RSV

TEST PREREQUISITES

Test oil : ISO-4113
 Test oil inlet temperature °C : 40.00...45.00
 Inlet pressure bar : 1.6
 Test nozzle holder combination : 1 688 901 013
 Opening pressure bar : 175
 Test pressure line
 Inner x Outer Dia - Length mm : 3.00 x 8.00 x 600

PORT CLOSING

Prestroke mm : 3.75 ± 0.05
 Rod position mm : -
 Port closing mark Cyl. No. : -
 Cam sequence : 1-5-3-6-2-4

 Port closing mark Cyl. No. : -
 Port closing difference °NW : 0-60-120-180-240-300

 Tolerance +- °C: 0.50 (0.75)



Injection Quantity :

Adjusting Point	Rack Pos. (mm)	P. Speed (rpm)	Injection Q'ty (cm ³ /1000 str.)	Difference (%)	Fixed	Remarks
A	10.2	1100	152.7 ± 2.0	± 3.0	Lever	Basic
H	approx. 6.5	350	12.0 ± 1.5	± 15.0	Rack	
A	10.2	1100	152.7 ± 2.0	-	Lever	Basic

Timing Advance Specification :

Pump Speed (rpm)					
Advance Angle (deg)					

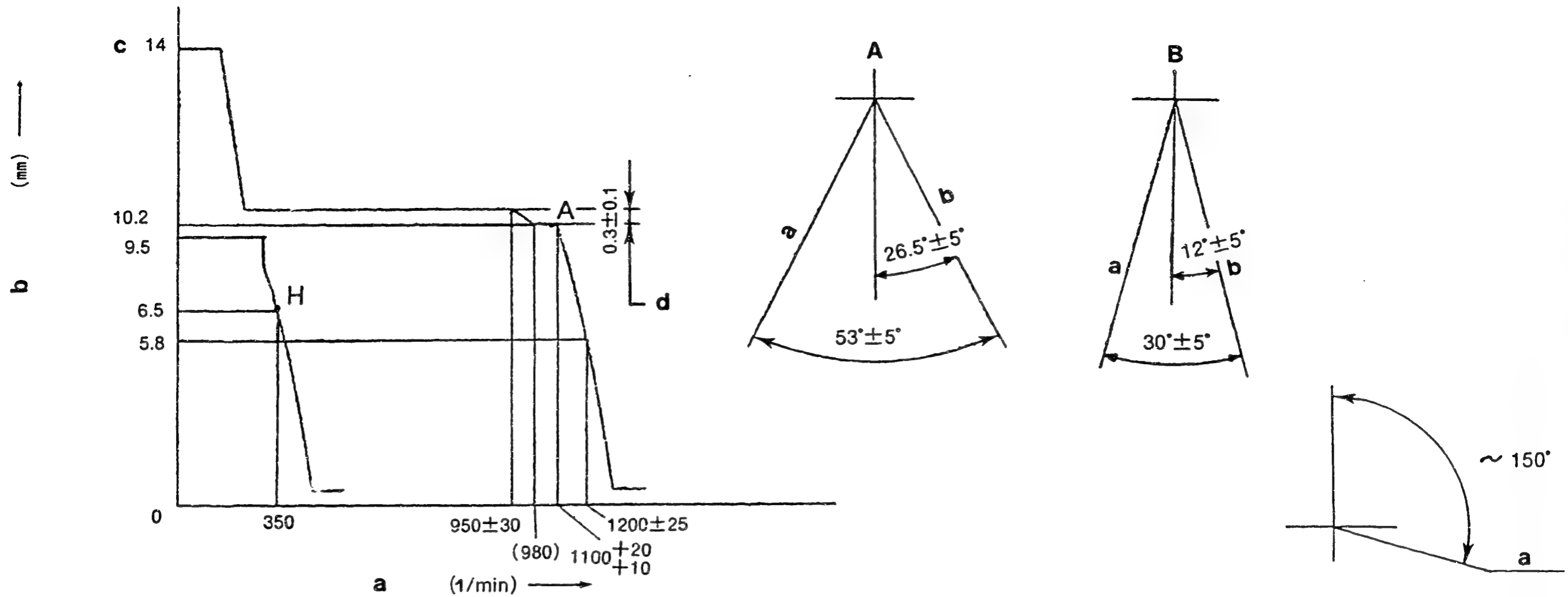

Figure 116

GOVERNOR ADJUSTMENT

Recommended speed droop adjustment screw position: 13

106692-4633 2/4

- a = Pump speed
- b = Control rack position
- c = Above
- d = Difference in control rack position between 1100 rpm and 700 rpm

- A = Stop Lever Angle**
- a = Stop
- b = Normal
- B = Speed Control Lever Angle**
- a = Idling
- b = Full-speed

TIMING SETTING

At No. 1 plunger's beginning of injection position.

a = Coupling key groove position

G13

ZEXEL - Test values
Injection pumps



G14

ZEXEL - Test values
Injection pumps



■ Note

- Before adjustment, remove the idling sub spring.
- Move the control lever fully in the stop direction, and set the minimum-speed stopper bolt so that the control rack position is 0.5 - 1.0 mm.

■ ADJUSTMENT

	Pump speed (rpm)	Rack position (mm)	Remarks
Full-load Adjustment (Temporary)	1300	10.2	<ul style="list-style-type: none"> • Adjust using screw (2) • Adjust using screw (1)
	600	10.2	
Torque Control spring Adjustment	850	10.5	<ul style="list-style-type: none"> • Adjust using spring capsule (4) • Confirm • Confirm the torque control stroke is 0.3 ± 0.1 mm
	950	10.5	
	980	10.2	
Idling Adjustment	0	9.5	<ul style="list-style-type: none"> • Fix the control lever • Adjust using spring capsule (5) • Confirm
	350	6.5	
	-	-	
Maximum-speed Adjustment	1100+20	10.2	<ul style="list-style-type: none"> • Fix the control lever • Confirm speed droop - adjust using screw (3) • Confirm
	+10 1200 \pm 25	5.8	
Full-load Adjustment	1100	10.2	<ul style="list-style-type: none"> • Confirm
Control Lever Angle Measurement	<ul style="list-style-type: none"> • Measure the control lever angle at the "idling" and "full" positions. • When the control lever is depressed toward the "full" position, replace the shifter's shim with a thicker one. • When the control lever is depressed toward the "idling" position, replace the shifter's shim with a thinner one. 		
Rack Limiter Adjustment	-	-	<ul style="list-style-type: none"> • Adjust using screw

G15

ZEXEL - Test values
Injection pumps



G16

ZEXEL - Test values
Injection pumps



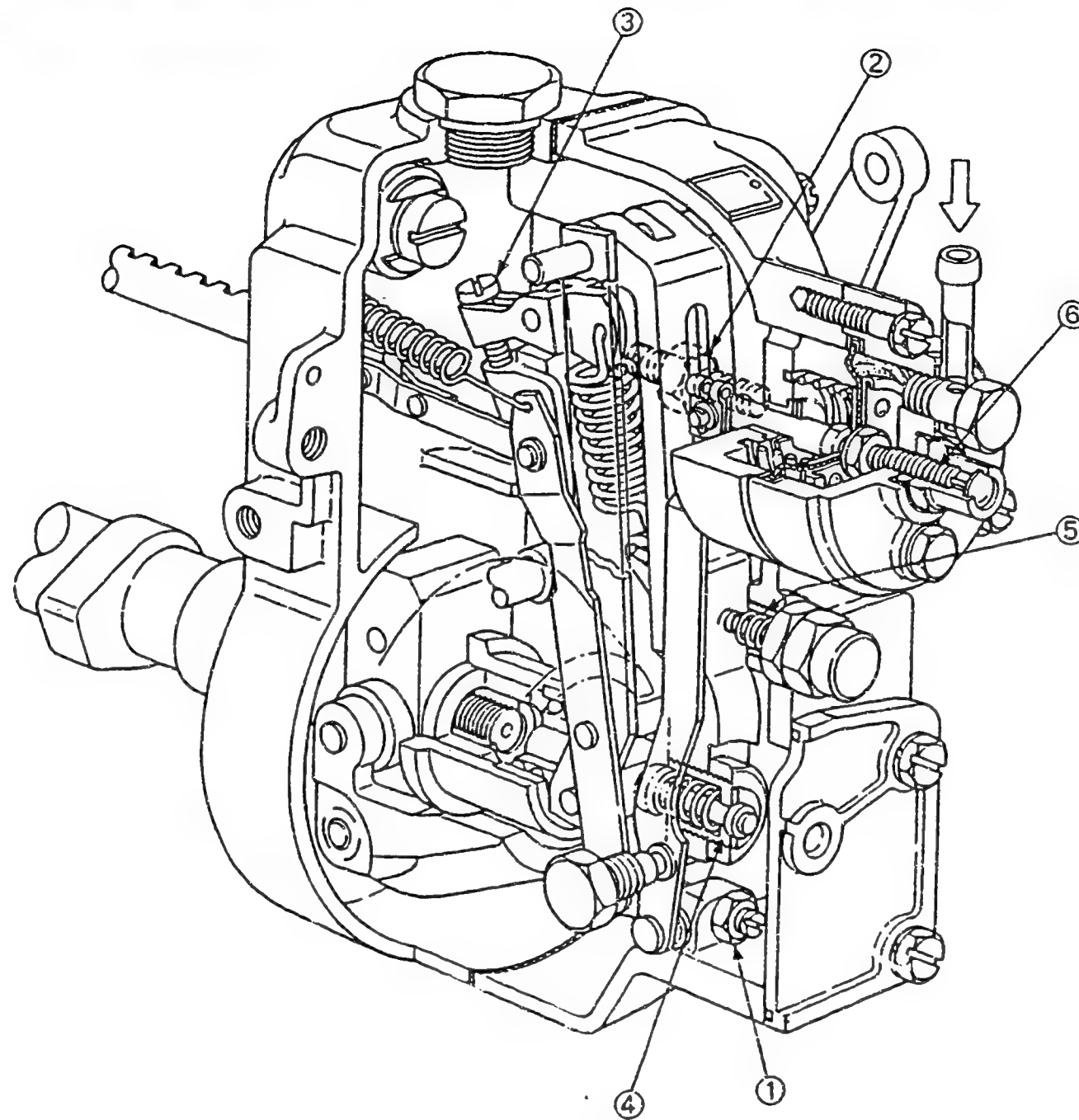

Figure 117

- 1 = Screw
- 2 = Screw
- 3 = Screw
- 4 = Spring capsule
- 5 = Spring capsule

106692-4633 4/4

G17

ZEXEL - Test values
Injection pumps



G18

ZEXEL - Test values
Injection pumps



ZEXEL - TEST VALUES
Injection pumps

BOSCH No.	:	9 400 610 237	1/4
ZEXEL No.	:	106692-4741	
Date	:	31.10.1992	[0]
Company	:	KOMATSU	
Engine	:	S6D170 / 6162-73-1582	

IP-Type number : 106069-8060 / PES6PD
Governor type number : 105448-9721 / EP/RSUV

TEST PREREQUISITES

Test oil : ISO-4113
Test oil inlet temperature °C : 40.00...45.00
Inlet pressure bar : 1.6
Test nozzle holder combination : 0 681 343 002
Opening pressure bar : 175
Test pressure line
Inner x Outer Dia - Length mm : 3.00 x 8.00 x 600

PORT CLOSING

Prestroke mm : 2.4 ± 0.05
Rod position mm : -
Port closing mark Cyl. No. : -
Cam sequence : 1-5-3-6-2-4

Port closing mark Cyl. No. : -
Port closing difference °NW : 0-60-120-180-240-300

Tolerance +- °C: 0.50 (0.75)

G19

ZEXEL - Test values
Injection pumps



Injection Quantity :

Adjusting Point	Rack Pos. (mm)	P. Speed (rpm)	Injection Q'ty (cm ³ /1000 str.)	Difference (%)	Fixed	Remarks
A	11.6	1000	289.0 ± 5.0	-	Rack	Basic Each cylinder
H	approx. 6.7	350	39.3 ± 5.0	± 10	Rack	
A	11.6	1000	289.0 ± 5.0	-	Lever	Basic
B	approx. 15	100	358.5 ± 10.0	-	Lever	Control rack limit

Timing Advance Specification :

Pump Speed (rpm)						
Advance Angle (deg)						

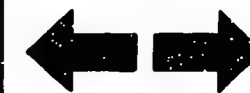

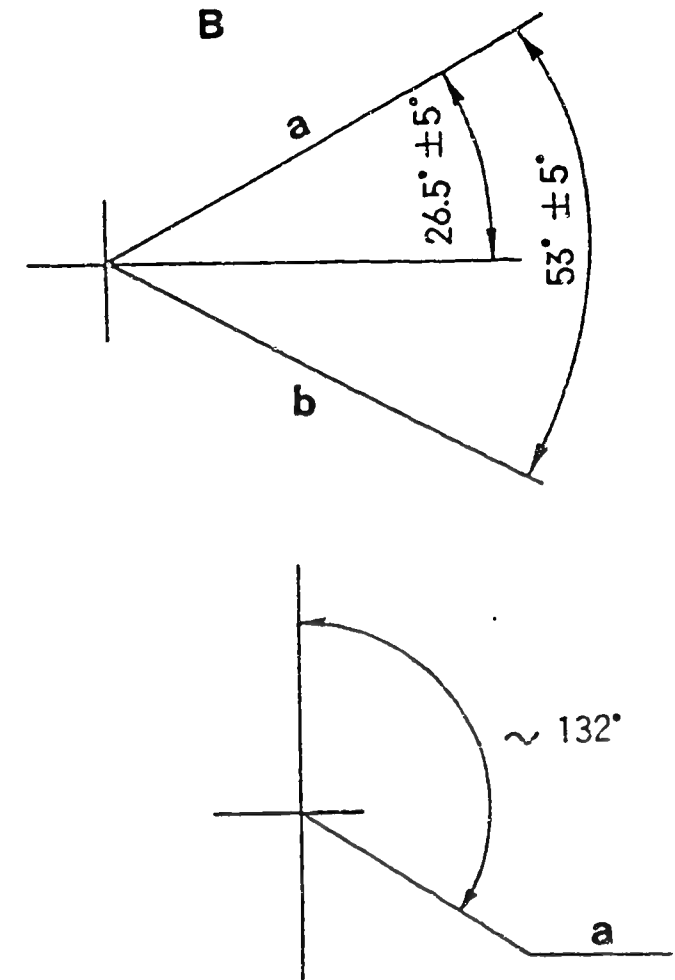
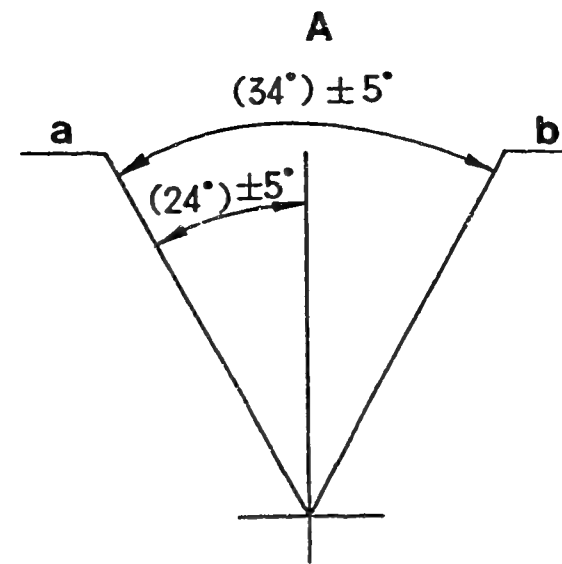
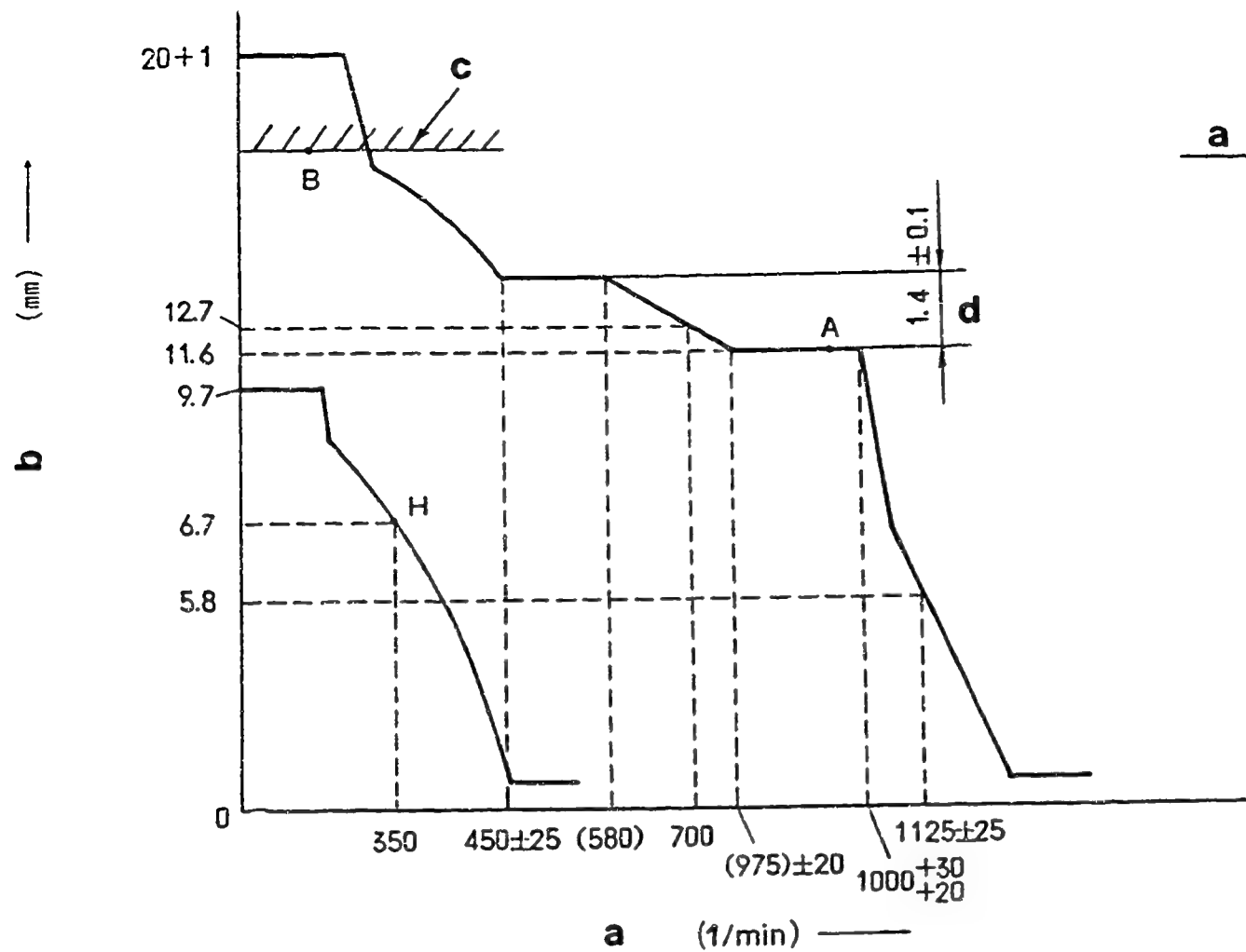

Figure 118

- a = Pump speed
- b = Control rack position
- c = Control rack limit:
- d = Difference in control rack position between 1000 rpm and 500 rpm

GOVERNOR ADJUSTMENT

Recommended speed droop adjustment screw position: 20

A = Speed Control Lever Angle

- a = Full-speed
- b = Idling

B = STOP LEVER ANGLE

- a = Normal
- b = Stop

■ TIMING SETTING

At No. 1 plunger's beginning of injection.

a = Gear coupling's aligning mark position (on key groove)



■ Note

- Before adjustment, remove the idling sub spring.
- Move the control lever fully in the stop direction, and set the minimum-speed stopper bolt so that the control rack position is 0.5 - 1.0 mm.

■ ADJUSTMENT

		Pump Speed (rpm)	Rack Position (mm)	Boost pressure kPa (mmHg)	Remarks
Full-load Adjustment (Temporary)		1200 700	11.6 11.6	-	<ul style="list-style-type: none"> • Adjust using screw (2) • Adjust using screw (1)
Torque Control Spring Adjust- ment	1.st stroke	450 ± 25	13.0	-	<ul style="list-style-type: none"> • Adjust using spring capsule (4) • Confirm • Confirm the torque control stroke is: (mm)
	2.st stroke	approx. 480 700 approx. 975±20	13.0 12.7 11.6	-	<ul style="list-style-type: none"> • Adjust using spring capsule (4) • Confirm • Confirm the torque control stroke is: 1.4 ± 0.1 mm
Maximum-speed Adjustment		1000+30 +20 1125 ± 25	11.6 5.8	-	<ul style="list-style-type: none"> • Fix the control lever • Confirm speed droop - adjust using screw (3) • Confirm
Boost Compensator System		-	-	-	<ul style="list-style-type: none"> • Fix the control lever • Adjust using screw (6) • Confirm the boost compensator stroke is: (mm)
Idling Adjustment		0	9.7	-	<ul style="list-style-type: none"> • Fix the control lever
1. Idling Sub Spring	H	350	6.7	-	<ul style="list-style-type: none"> • Adjust using spring capsule (5) • Confirm
2. Control Lever	-	-	-	-	<ul style="list-style-type: none"> • Adjust using the control lever • Confirm
Full-load Adjustment		1000	11.6	-	<ul style="list-style-type: none"> • Confirm
Control Lever Angle Measurement		<ul style="list-style-type: none"> • Measure the control lever angle at the "idling" and "full" positions. • When the control lever is depressed toward the "full" position, replace the shifter's shim with a thicker one. • When the control lever is depressed toward the "idling" position, replace the shifter's shim with a thinner one. 			
Control Rack Limiter Adjustment		0	approx. 15	-	<ul style="list-style-type: none"> • Adjust using screw

G24

ZEXEL - Test values

Injection pumps



G25

ZEXEL - Test values

Injection pumps



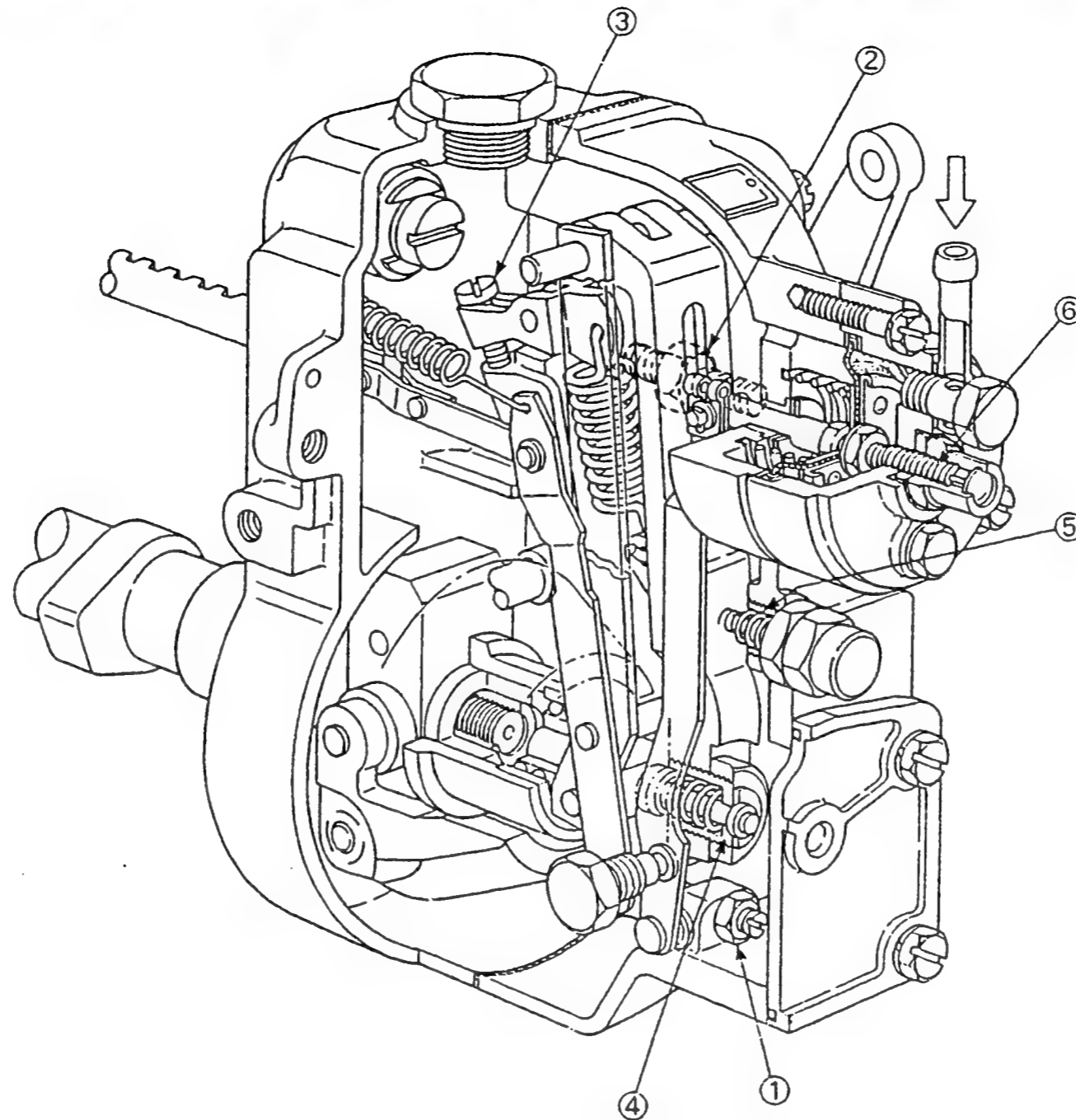

Figure 119

- 1 = Screw
- 2 = Screw
- 3 = Screw
- 4 = Spring capsule
- 5 = Spring capsule
- 6 = Screw

106692-4741 4/4

G26

ZEXEL - Test values
Injection pumps



G27

ZEXEL - Test values
Injection pumps



ZEXEL - TEST VALUES
Injection pumps

BOSCH No.	:	9 400 610 238	1/4
ZEXEL No.	:	106692-4752	
Date	:	31.10.1992	[0]
Company	:	KOMATSU	
Engine	:	S6D125 / 6151-71-1450	

IP-Type number : 106069-5420 / PE 6P
Governor type number : 105407-3702 / EP/RSV

TEST PREREQUISITES

Test oil : ISO-4113
Test oil inlet temperature °C : 40.00...45.00
Inlet pressure bar : 1.6
Test nozzle holder combination : 1 688 901 013
Opening pressure bar : 175
Test pressure line
Inner x Outer Dia - Length mm : 3.00 x 8.00 x 600

PORT CLOSING

Prestroke mm : 3.75 ± 0.05
Rod position mm : -
Port closing mark Cyl. No. : -
Cam sequence : 1-5-3-6-2-4

Port closing mark Cyl. No. : -
Port closing difference °NW : 0-60-120-180-240-300

Tolerance +- °C: 0.50 (0.75)

H1

ZEXEL - Test values
injection pumps



Injection Quantity :

Adjusting Point	Rack Pos. (mm)	P. Speed (rpm)	Injection Q'ty (cm ³ /1000 str.)	Difference (%)	Fixed	Remarks
A	10.2	1100	152.7 ± 2.0	± 3	Lever	Basic
H	approx. 6.5	350	12.0 ± 1.5	± 15	Rack	
A	10.2	1100	152.7 ± 2.0	-	Lever	Basic

Timing Advance Specification :

Pump Speed (rpm)						
Advance Angle (deg)						

H2

ZEXEL - Test values
Injection pumps



H3

ZEXEL - Test values
Injection pumps



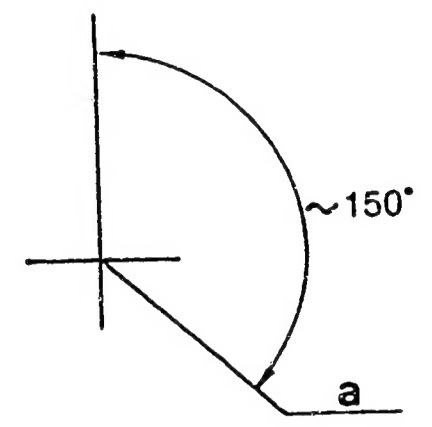
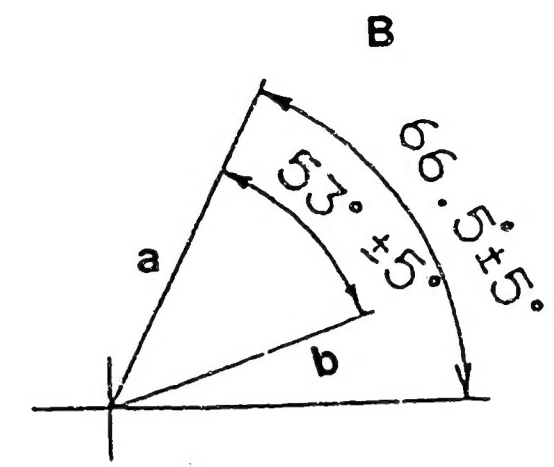
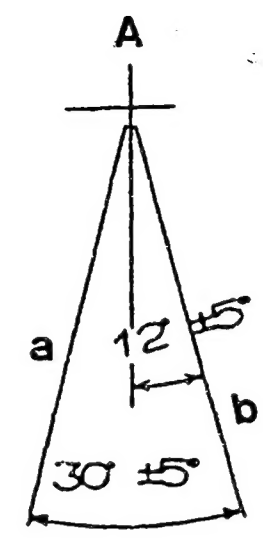
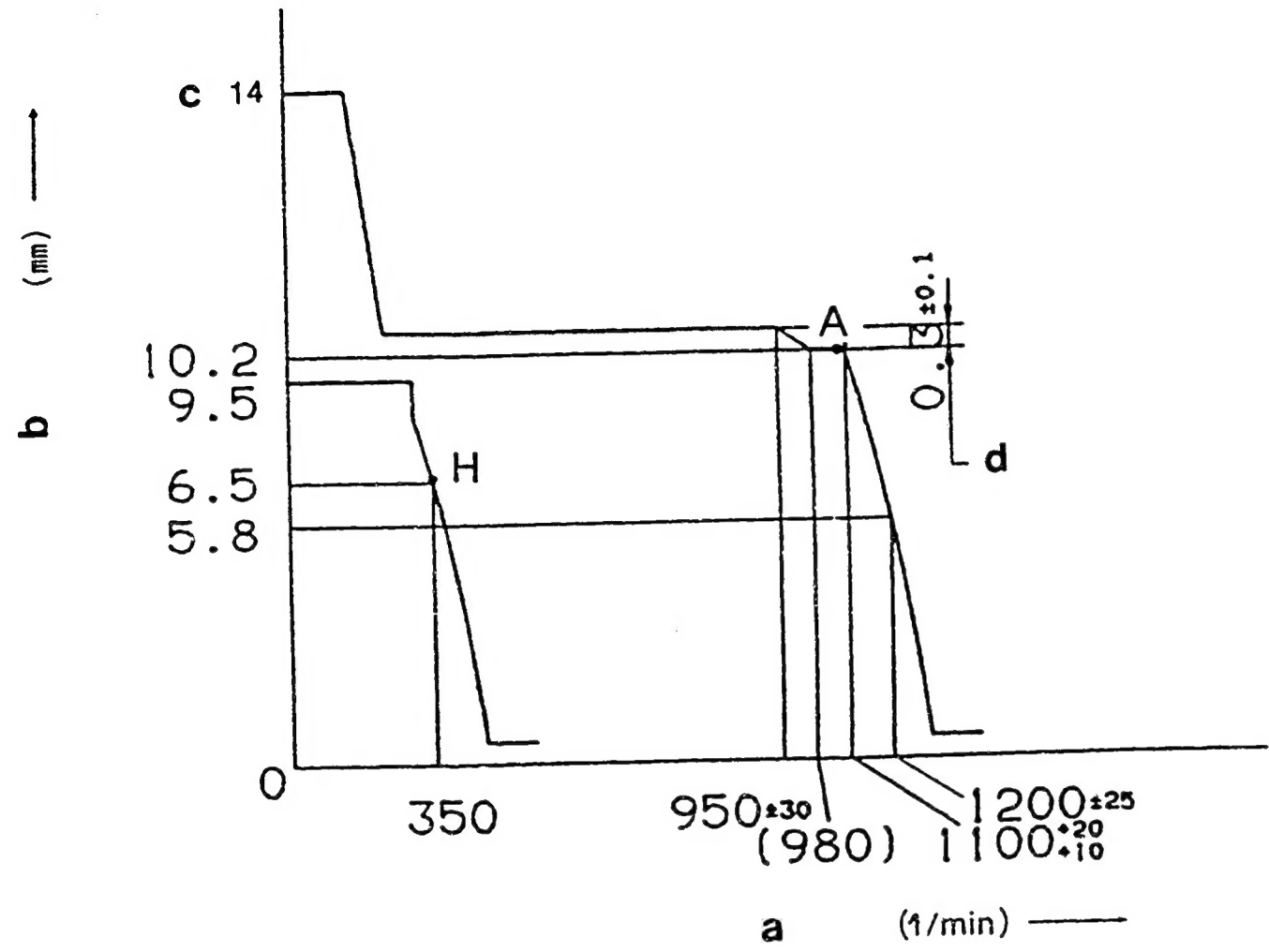

Figure 120

GOVERNOR ADJUSTMENT

Recommended speed droop adjustment screw position: 13

106692-4752 2/4

- a = Pump speed
- b = Control rack position
- c = Above
- d = Difference in control rack position between 1100 rpm and 700 rpm

A = Speed Control Lever Angle

- a = Idling
- b = Full-speed

B = STOP LEVER ANGLE

- a = Normal
- b = Stop

■ TIMING SETTING

At No. 1 plunger's beginning of injection.

a = Coupling key groove position

■ Note

- Before adjustment, remove the idling sub spring.
- Move the control lever fully in the stop direction, and set the minimum-speed stopper bolt so that the control rack position is 0.5 - 1.0 mm.

■ ADJUSTMENT

		Pump Speed (rpm)	Rack Position (mm)	Boost pressure kPa (mmHg)	Remarks
Full-load Adjustment (Temporary)		1300 700	10.2 10.2	-	<ul style="list-style-type: none"> • Adjust using screw (2) • Adjust using screw (1)
Torque Control Spring Adjust- ment	1.st stroke	approx. 850 950 ± 30 approx. 980	10.5 10.5 10.2	-	<ul style="list-style-type: none"> • Adjust using spring capsule (4) • Confirm • Confirm the torque control stroke is: 0.3 ± 0.1 mm
	2.st stroke	-	-	-	<ul style="list-style-type: none"> • Adjust using spring capsule (4) • Confirm • Confirm the torque control stroke is: (mm)
Maximum-speed Adjustment		1100+20 +10 1200 ± 25	10.2 5.8	-	<ul style="list-style-type: none"> • Fix the control lever • Confirm speed droop - adjust using screw (3) • Confirm
Boost Compensator System		-	-	-	<ul style="list-style-type: none"> • Fix the control lever • Adjust using screw (6) • Confirm the boost compensator stroke is: (mm)
Idling Adjustment		0	9.5	-	<ul style="list-style-type: none"> • Fix the control lever
1. Idling Sub Spring	H	350	6.5	-	<ul style="list-style-type: none"> • Adjust using spring capsule (5) • Confirm
2. Control Lever	-	-	-	-	<ul style="list-style-type: none"> • Adjust using the control lever
Full-load Adjustment		1100	10.2	-	<ul style="list-style-type: none"> • Confirm
Control Lever Angle Measurement		<ul style="list-style-type: none"> • Measure the control lever angle at the "idling" and "full" positions. • When the control lever is depressed toward the "full" position, replace the shifter's shim with a thicker one. • When the control lever is depressed toward the "idling" position, replace the shifter's shim with a thinner one. 			
Control Rack Limiter Adjustment		-	-	-	<ul style="list-style-type: none"> • Adjust using screw

H6

 ZEXEL - Test values
 Injection pumps

H7

 ZEXEL - Test values
 Injection pumps

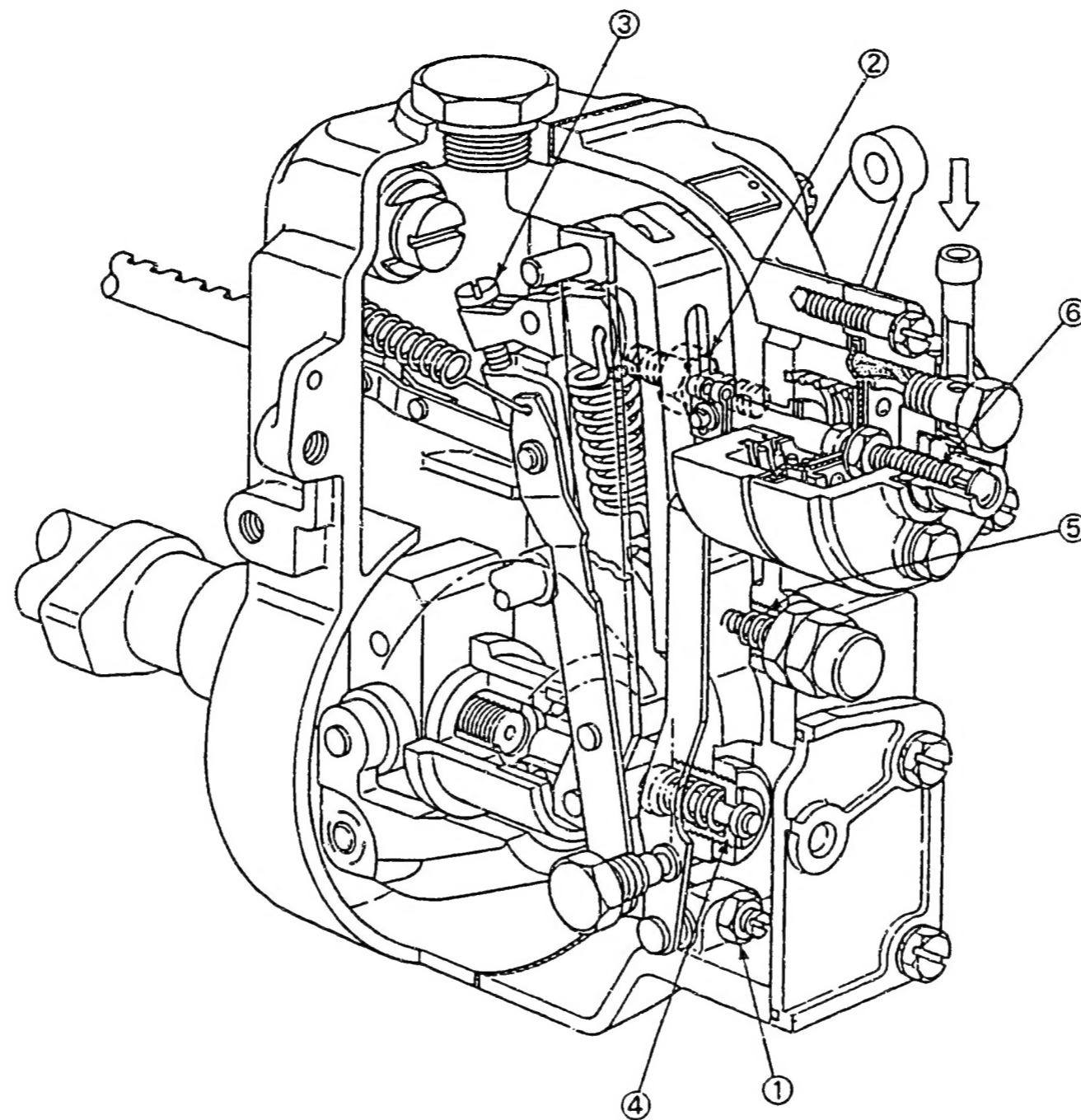



Figure 121

- 1 = Screw
- 2 = Screw
- 3 = Screw
- 4 = Spring capsule
- 5 = Spring capsule
- 6 = Screw

106692-4752 4/4

H8

ZEXEL - Test values
Injection pumps



H9

ZEXEL - Test values
Injection pumps

